

# Feasibility Study of Using Super capacitors as Storage devices in Photovoltaic Systems

T. Zouaghi<sup>1</sup>, B. Issaoui<sup>1</sup>, A. Schmitt<sup>2</sup>, M. LeBitoux<sup>2</sup>

<sup>1</sup>Laboratoire des Systèmes Electriques

ENIT, Tunis –Elmanar University

B.P 37, 1002 Tunis (Tunisia)

Phone: ++216 71 874700, fax:++ 216 71872729, e-mail: [t.zouaghi@enit.rnu.tn](mailto:t.zouaghi@enit.rnu.tn)

<sup>2</sup>Ecole de l'Aviation de Borj el-Amri, km20, Route Medjez el-Bab, Tunis (Tunisia)

Department of Research and Development

<sup>2</sup>EDF / DRD

1, avenue du Général de Gaulle, 92141, Clamart – Cedex (France)

**Abstract.** One of the isolated PV set power supply disadvantage is the low level of energy, which considerably limits the powered applications. The aim of this paper deals with supercapacitor utilization in such installations so to solve the power limitation problem. The study shows that this idea worth going into, but not yet mature considering the economic point of view. Supercapacitor technology is improving rapidly nowadays, we are confident that in the near future, this application should be viable.

## Key words

PV Systems, Renewable Energy, Electrical Storage Devices, Supercapacitors

## 1. Introduction

With the electric vehicle advent, the rapid development of technologies during the last decades led to consider new solutions for electrical energy storage. Classical means are usually insufficient for power systems supply. They are either not powerful such as batteries and accumulators which allow a relatively high autonomy with low specific power, or rather powerful like condensators with high specific power but their autonomy is insufficient for powered applications.

In this context, super capacitors (SC) have been developed since few decades and considered as complementary energy sources for batteries (for example) so as to make them rather powerful. Researchers and constructors have performed several types of SC with different properties and applications. The SC are intermediate between electrochemical accumulators and classical condensators; their capacitances and their specific power could rise hundreds of times the classical ones, but their energy densities are ten times lower. Their life duration is much higher thanks to their electrostatic operation principle. Thanks to the improvements, which have been performed in terms of energy density during the last

years, the SC could, for mean and high power levels, replace lead accumulators. Thus, we could get rid of maintenance and life duration battery problems, with the advantage that the SC characteristics may be permanently online controlled; this is not possible with accumulators.

In electrotechnics, a very interesting application could rise thanks to recent developments of SC: the implementation of localized high-powered sources for electrical motors. This would allow diminution of supply sources and wires sizing; as well as the electromagnetic perturbation suppression (for transitories going from few tens of milliseconds to few tens of seconds).

In this paper, we are interested on energy storage in isolated sites supplied by photovoltaic sources application. This may be out of applications for which the SCs are generally dedicated, but we really think that this solution will be seriously considered in the future.

## 2. Principle, Constitution and Characteristics of SC

The principle of SC is nearly the same than the electrochemical accumulators one [1]: two electrodes in an electrolyte (Fig. 1). Different types of electrodes lead to different types of SC, such as active carbon electrodes with great specific surface (thousands of m<sup>2</sup>/g); the electricity is stored at the electrode - electrolyte interface (electrochemical double layer phenomena discovered by Helmholtz in 1879), the operation is purely electrostatic. This allows to have hundreds of farads/g of capacitances. The electrolyte may be of two sorts: organic or aqueous. The former provides a relatively high cell voltage (~3 V), which allows a high density of energy; the later, due to its high conductivity, allows high levels of specific power [3]. Nowadays, an energy density of about several tens of Wh/kg, and a power density of about several kWatts/kg, are performed. This type of SC offers a low potential cost and a long lifetime thanks to their electrostatic operation; their applications should be promising [4]. A

comparison of Characteristics of the main SC types is given in Appendix – TABLE I.

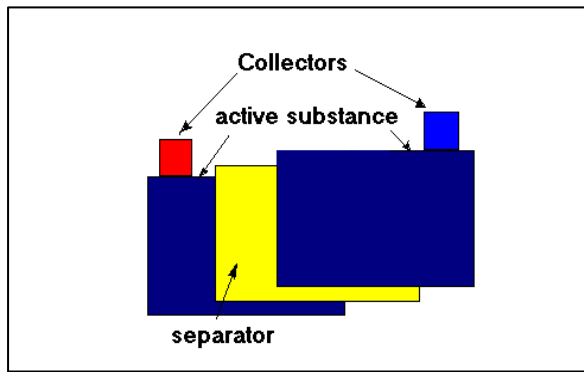

Fig. 1 Supercapacitor constitution principle scheme

### 3. PV Energy Storage Application

Fig. 2-a shows the electrical scheme of a PV cell and its performance curve (fig. 2-b). It shows the optimum zone where the PV generator should operate, so to have the maximum of delivered power. It will be seen that it is not always possible and an adaptation circuit is necessary, especially if we intend to use super capacitors.

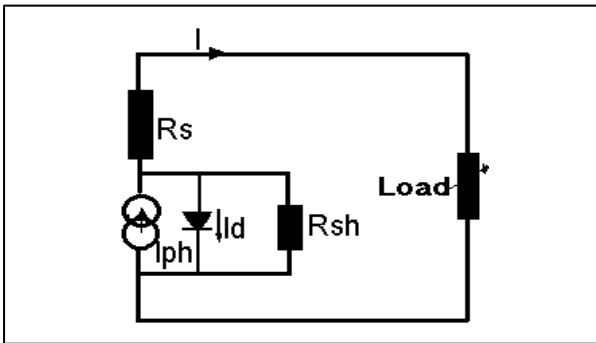

Fig. 2 Electrical scheme of a photovoltaic cell

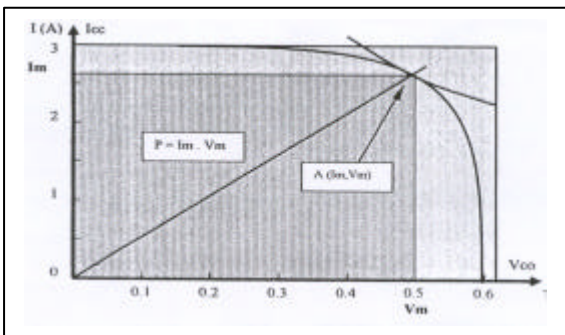

Fig. 2-b Power Characteristic ( $I = f(V)$ ) of a PV block set

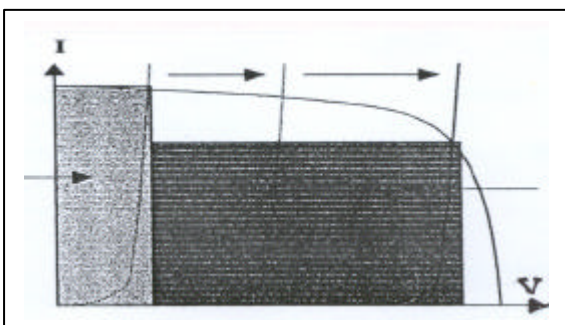

Fig. 2-c PV cell – SC Operating Characteristic

In the present paper, we are interested on SC potential application for energy storage in isolated sites supplied by PV generators, Fig. 2-c shows the presumed operating characteristic of such a system. Generally, in PV applications, the storage device is used as a buffer adapting the generator to the load. From this point of view, batteries are well adapted to this principle since they provide a nearly constant voltage during normal operation (Fig. 3-a); it is easier to adjust the systems operating point in the optimum zone [2] (Fig. 3-b). This would be different with the SC because of their variable voltage. The PV generator has to operate progressively in low power domains with low efficiencies. In fact, this constitutes the major disadvantage of SC utilization. Thus, an appropriate mean for adapting the PV generator to SC must be performed. One of the solutions is to use a chopper for adaptation with a capacitance for output voltage regulation (Fig. 4).

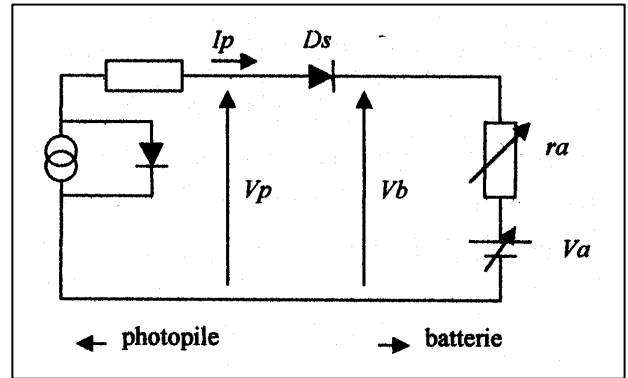

Fig. 3-a Photovoltaic cell – battery link

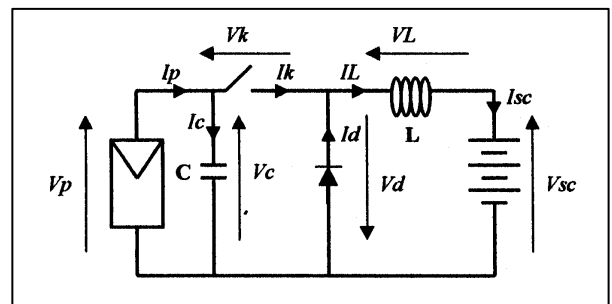
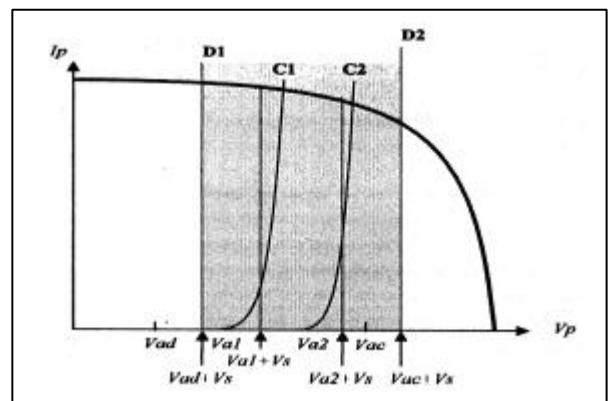

Fig. 3-b Photovoltaic cell – battery operation characteristic

Fig. 4 Adaptation circuit scheme with dc-dc converter

#### 4. Studied System Dimensioning

##### A. Energetic Dimensioning

Once, the different elements of the PV chain are defined (from the captor to the supplied load), we have to define the characteristics of each of them. For the purpose of dimensioning we have to consider, in one hand, the energy demand and the solar provided energy, on the other hand the intermediary energy managing. To well approach the feasibility and the adaptability of SC in PV systems, we considered at first, a simple case of a diesel micro-power station with a synchronously coupled PV sub-system with the following characteristics: rated power:  $P = 1kW$ ; daily energy consumption  $C_d = 3.5 kWh/day$ ; autonomy: 2 days; DC output supply: 48 V; AC output supply: 230 V / 50 Hz.

Energetic dimensioning was facilitated thanks to a commercial numerical package called **PVDIMENS** witch is rather simple of utilization; it allows to dimension a PV system including a PV generator (PV cell panel), a load regulator and an electrical energy storage device.

Firstly, we have proceeded to a pre-dimensioning task with an estimated efficiency value in order to have an approximated value of SC power. Then, a more accurate dimensioning calculation could be done. The results are the following:

##### B. Dimensioning Example of one studied system element -adaptation regulator-

Fig. 4 shows the principle of adaptation we used ( an electromagnetic relay could be inserted, so to have better voltage regulation). In this case, Fig. 5-a shows the SC – PV system operating performance curve with negative booster, where we could notice the optimal functioning zone.

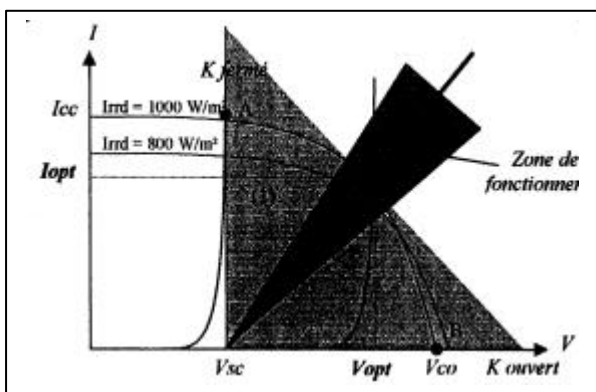

Fig. 5-a Sc – Pv Operating Performance Curve with Adaptation Negative Booster

Fig. 5-b shows the same thing with a positive booster,

Pv generator:

- Estimated efficiency for each regulator = 90%
- Autonomy: 2 days
- Pv panel type: NAPS
- Peak power 11Wc
- Voltage 12 V
- SC: Alcatel-alsthom
- Active carbon electrode (3000 m<sup>2</sup> / g)
- Organic electrolyte
- Volume: 11.7 cm<sup>3</sup>
- Weight: 5.6 g
- Nominal capacitance: 5.6 F; (.05 Ah)
- Internal resistance: 1.5 Ω
- Vmax = 3V
- Stored energy: 0.07 Wh (12 Wh / kg)
- Pmax = 1.5 W (270 W / kg)
- Efficiency: 0.9
- Required peak power: Pc = 1467 Wc
- Required SC Capacitance: 52 Ah
- Nominal sunny period (annual average per 1m<sup>2</sup> of PV panel): 4.8kWh / m<sup>2</sup>.J
- Nominal voltage: Vco = 300 V<sup>-</sup>;

Adapting converter: IGBT(IRGBC20U-IR):

- Vmax=450 V;
- Imax=6.75 A

Free wheel diode (fast recovery – 12FL60S02 – IR):

- Vrrm=450 V;
- Iavmax=6075 A

Output capacitance: 51.2 nF / 450 V

Smoothing inductance: 1.3 mH

Semiconductor losses: 43.76

this device is not adapted to our problem.

Other more perform ant devices could either be utilized for purpose of adaptation; this is not the mater of our study, we just look here the feasibility of such a system; further improvements should be studied later.

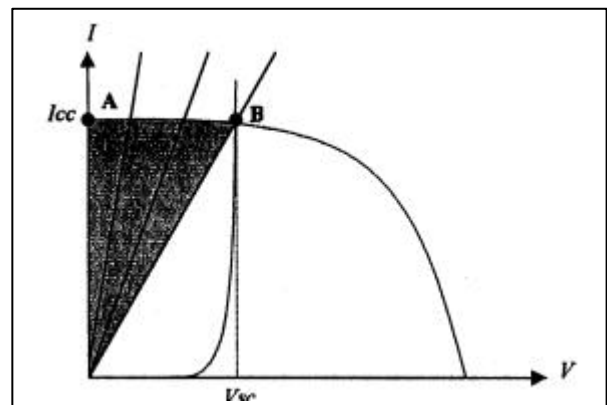

Fig. 5-b Sc – Pv Operating Performance Curve with Adaptation Positive Booster

As for the energetic dimensioning, we shall have the following data:

- ♦  $I_{cc} = P_c / V_{co} = 4.89 A$ , we take  $I_{opt} = 4.5 A$  ;

- ◆  $V_{co} = 300V$ , we take  $V_{opt} = 297V$  ;
- ◆  $P_c = 1467W_c$  : input power source

IGBT :

- ✓  $V_{max} = 303V$ , with a security coefficient of 50%, we take :  $V_{max} = 450V$  ;
- ✓  $I_{max} =$  with a security coefficient of 50%, we take  $4.5A$ , :  $I_{max} = 6.75A$  ;
- ✓ **IRGB120U IR**

Free Wheel Diode :

- ✓  $V_{rrm} = 450V$ , same security coefficient;
- ✓  $I_{moy max} = 6.75A$ , same security coefficient;
- ✓ Diode (fast recovery) **12FL60S02 of IR**

Smoothing Inductance:

- ✓ We adopted a security margin of 50% interrupters, we tolerate:  $\Delta IL_{max} = \frac{V_{opt}}{4LF} = 30\%$  of  $I$  average, Where the frequency  $F = 40 KHz$  and  $L = 1.3mH$

Capacitance of the load:

- ✓ For the same reasons than above we tolerate voltage ripple of :  $\Delta V_{max} = \frac{\Delta IL_{max}}{8CF} = 30\%$ ,
- ✓  $C = 51.2nF / 450V$ .

Semi-conductors losses :

- ✓ IGBT conduction loss:  $P_1 = 5 * 4.5 = 22.5 W$ .
- ✓ IGBT switching loss:  $P_2 = 0.35mJ * 40KHz = 14W$ .
- ✓ Diode conduction loss :  $P_3 = 1.4 * 4.5 = 6.3 W$ .
- ✓ Diode switching loss :  $P_4 = Q_r * V_{rrm} * F = 0.08I_c * 303 * 4.10^4 = 0.96W$  ;
- ✓ Total losses :  $P_t = 22.5 + 14 + 6.3 + 0.96 = 43.76W$

Efficiency :  $\eta = 1 - \frac{43.76}{1467} = 0.97$

### C. Some Elements of Voltage Inverter Dimensioning

We assume a power factor  $\cos \phi \approx 0.8$ , thus the voltage ratio is:

◆  $m = \frac{n_2}{n_1} = \frac{230}{2(48-3)} = 2.56$  ; Taking into account

the voltage drop in the IGBT

- ◆  $P_s = 1500W$  : load power;
- ◆  $V_e = 48V$  : inverter input voltage ;
- ◆  $V_{seff} = 230V$ ;  $V_{smax} = 325V$ : inverter output maximum and rms voltages;
- ◆  $I_{smax} = 2P_s / V_{smax} \cdot \cos \phi = 12 A$ : maximum load current;
- ◆  $I_{seff} = P_s / V_{seff} \cdot \cos \phi = 7,2 A$  : rms load current

All these data allow the inverter dimensioning.

## 5. Simulation of the System Operation

Fig. 6 and 7 show respectively, the power characteristic of the PV block set and the operation characteristics of the PV panel associated to the SC device. Fig. 8 and 9 show respectively the motion of system characteristics

as function of time for a "sunning intensity" of  $1000W/m^2$ , respectively for  $1500W/m^2$ .

## 6. Result Analysis

This study leads us to the following remarks:

- To ensure sufficient energy, the power of installed SC is too much; as they have too small internal resistances, this may be dangerous in case of short-circuit ( $I_{cc} = 1.13 kA$  for the studied system).
- The regulators have better efficiencies at high power levels.

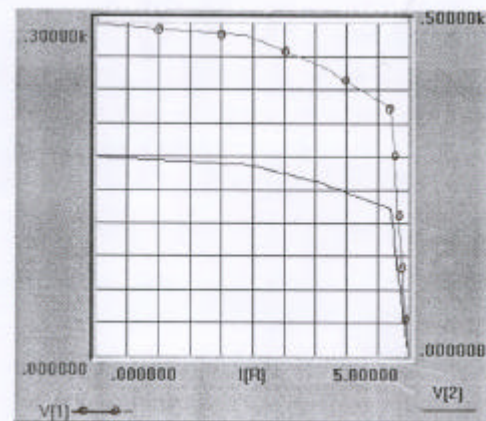

Fig. 6 operating characteristics of Pv panel associated to a Sc

V(1): Panel terminals voltage (kV); V(2): SC voltage (kV);

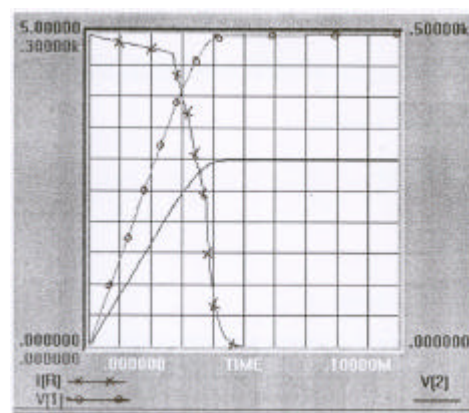

Fig. 7 Motion of the system characteristics function of time

(Sunning Intensity:  $1000 W/m^2$ )

V(1): Panel terminals voltage (kV); V(2): SC voltage (kV); I(R): Pv panel provided current (A)

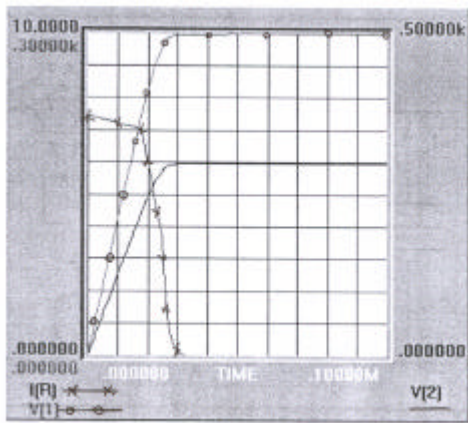

fig. 8 Motion of the system characteristics function of time  
(Sunning Intensity: 1500 W/m<sup>2</sup>)  
V(1): Panel terminals voltage (kV); V(2): SC voltage (kV);  
I(R): Pv panel provided current (A)

An economical study has also been carried out, but we have no conclusion to say because the SC costs are not yet stabilized. Such a study should be done in the future when SC prices are more significant.

## 6. Conclusion

As a conclusion, SC storage application could be interesting in powerful PV installations such as water pumping systems or motorised workshops... However, some technical problems remain. Nevertheless, this studies allows us to have a better idea on SC utilization and limits.

As the development of SC is rapidly moving on nowadays, we are confident that this technique will be satisfactory in the near future.

Till now, a hybrid solution ( SC + batteries) could be reliable for powered PV applications. All these items should be more detailed and discussed in further studies in the future.

## Acknowledgement

This work has been supported by the Research & Development Division of Electricité de France (EDF/DRD) at Clamart, we thank gratefully all the people of "Groupe Alimentation"- "Postes et Lignes", for their valuable contribution.

## References

- [1] J. F. Fauvarque "Les Supercondensateurs à double couche électronique" in proceedings of the "Journées d'Etude sur les Supercondensateurs-JESC", CNAM – Paris – France, Feb. 5-6, 1998.
- [2] F. Fabero, N. Vela, M. Alonso, J. Cuenca, "Validation of Theoretical Model for different PV Batteries" in Proceedings of the 14<sup>th</sup> European Photovoltaic Solar Energy Conference, Barcelona – Spain – 1997.
- [3] X. Andrieu, L. Josset, B. Pichon, "A high Energy Density Capacitor", in proceedings of the Fall Meetings of the Electrochemical Society, San Antonio TX, USA, Oct. 7-11, 1996.
- [4] A. Rudge, J. Davey, I. Raistrick and S. Gottesfeild, "Conducting Polymers as Potential Active Materials in Electrochemical Supercapacitors", the second International Seminar on double layer Capacitors and Similar Energy Storage Devices, Florida, USA, Dec. 1992.
- [5] R. Bausière "les convertisseurs en électronique de puissance – la conversion continu – continu" T. & D. Lavoisier, Paris (1987)
- [6] H. Bühler "Electronique de Réglage et de commande" Dunod, Paris (1987).
- [7] G. Séguier "L'électronique de puissance" Dunod, Paris (1990).
- [8] J. C. Mauclerc "Guide du technicien enélectronique" Hachette, Paris (1995).

Appendix – TABLE I. - Compared Different types of Sc Characteristics [1,2,3,4]

	Activated charcoal Sulphuric. Acid	Activated charcoal Organic electrolyte	Metal Oxides / Sulphuric. Acid	Conduct. Polymers Organic electrolyte
Energy Density	0.7 - 4 kJ/kg	2-20(→40) kJ/kg	10 - 20 kJ/kg	10(→ 40) kJ/kg
Power Density	1 - 10 kW/kg	0.1 - 2 kW/kg	10 - 100 kW/kg	100 W/kg
Voltage	0.8 - 1.2 V	2.3 - 3 V	0.8 -1.2 V	1.3(→2.5V)
Cyclability	> 100000	> 100000	> 100000	10000→100000
Cost	Low	Low	High	-



