

# Microgrid control system architecture for improving energy efficiency and demand response integration

Guillermo Escrivá-Escrivá<sup>1</sup>, E. C. W. de Jong<sup>2</sup>, Carlos Roldán-Blay<sup>1</sup>

<sup>1</sup> Institute for Energy Engineering  
 Universitat Politècnica de València  
 Camino de Vera, s/n, edificio 8E, escalera F, 2a planta, 46022 Valencia, Spain

<sup>2</sup> DNV KEMA (Flex Power Grid Lab)  
 Utrechtseweg 310, 6812AR Arnhem, the Netherlands

## Abstract.

Smart-grids have several advantages over conventional electrical energy distribution systems. On the one hand, they enable smart measuring and control of both, consumption and energy production. On the other hand, they contribute to the integration of renewable energy sources, distributed energy resources and demand response. However, some aspects of smart-grids have not been solved, such as the control of all the components. In this study, some control equipments have been analyzed to establish the control system architecture. As a result of the tests shown in this paper, a suitable design of the control system of a micro-grid is proposed. The power meters, quality analyzers and programmable logic controller to be used in the micro-grid control system have been tested to ensure their suitability for this purpose.

## Keywords

Smart-grids, Micro-grids control system, Energy management system, Demand response.

## 1. Introduction

Along the last years, the concept of smart-grids has become very important and a lot of research related to the design, the control and other aspects has been developed. As regards the control system, it can be designed in order to reach different **goals**, such as minimizing CO<sub>2</sub> emissions, minimizing the total cost, maximizing the use of the available renewable resources, and so on [1]. Some components must be present in the control system, like power meters and quality analyzers, but first, they should be tested under some special conditions to ensure they are suitable for the use in smart-grids control systems. For this reason, some of these devices have been tested to propose a reliable design of the control system of a micro-grid.

Smart-grids have been developed to promote the use of renewable energy sources and maximize the use of the available demand resources. The main advantages of the

micro-grids over conventional energy distribution systems are:

- Micro-grids try to improve economic performance and operating aspects of networks.
- The system becomes more flexible.
- Micro-grids promote the use of renewable energy thus reducing environmental impact.
- The distances between generation and consumption are shortened, which reduces losses in transmission and distribution.
- The decentralization of generation increases the reliability and quality of services, as there is less reliance on a few generators and on transmission and distribution lines.
- Micro-grids enable the introduction of many new companies, thus reducing the market power of large established companies and increasing the number of jobs.
- Micro-grids increase safety since they use a larger number of protections.
- Micro-grids promote quality networking and differentiated services.

However, there are some problems that have not been solved already related to the control [2,3], the protection [4-6] and the load flow [7].

Figure 1 shows the basic architecture of a micro-grid.

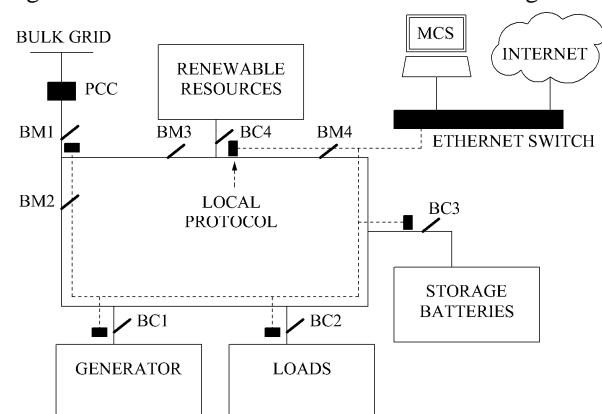

Fig. 1. Basic architecture of a micro-grid.

BMi are breakers installed for management purposes and BCi are breakers installed for connecting the different components of the micro-grid.

The control system of the micro-grid is one of the most important components, since it enables the grid operation. But a micro-grid can work in isolated island configuration or connected to a power system, thus the control system must be complex and reliable [8-11].

Two main criteria are taken into account for the design of the control system architecture:

- Improvement of energy efficiency of the components that constitute the micro-grid.
- To provide the integration of different distributed resources acting as a demand response resource.

Due to the size of a micro-grid and the type of energy sources and loads connected, control equipment must be able to operate under certain special conditions, which have been studied in a laboratory. The results are shown in later sections.

All studies have been carried out on the basis of the micro-grid available in the Labder laboratory, at the

Universitat Politècnica de València, with the available control equipment and power generation and load connected to this experimental micro-grid.

Section 2 describes the micro-grid installed in the Labder. Section 3 describes the proposed control system architecture. Section 4 shows the control system validation. Finally, some conclusions are shown in section 5.

## 2. UPV micro-grid description

Labder is an R&D laboratory designed to integrate renewable energy sources. A micro-grid has been prepared in this laboratory to analyze the control system design and the interaction between each component. This micro-grid has a Xantrex inverter used to join all the components and distribute the energy flow. This device is connected to the bulk grid, the renewable resources and variable and programmable loads.

Figure 2 shows the Labder micro-grid layout.

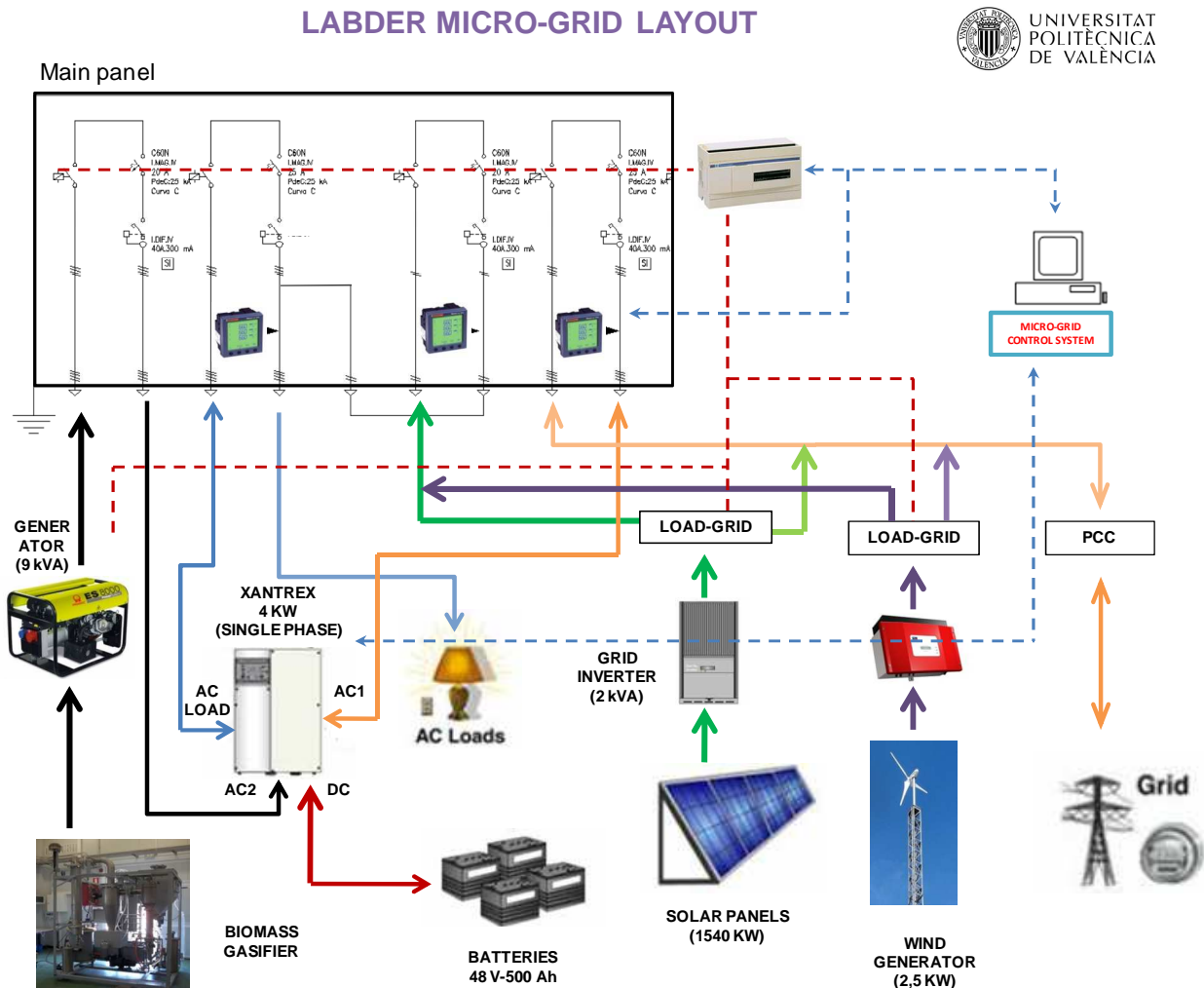

Fig. 2. Labder micro-grid layout.

The characteristics of the components of this micro-grid are:

- 2 solar panels USP 145 (150W), 4 solar panels Wanxiang Solar 180s and 5 solar panels REC Solar 230 AE, with an available active power of 1540 W.
- A wind generator Siliken Wind 3.5 GT that can generate 2500 W.
- A biomass gasifier with a generator PRAMAC P 12000 with 9 kVA of power.
- 4 batteries Classic EnerSol 250 (48 V) with a total capacity of 500 Ah.

- A Xantrex XW4548 charger/inverter to make all the connections between the grid, the loads and the components of the micro-grid.

### 3. Proposed control system architecture

The proposed control system has the following components:

- Power meters 710 by Schneider Electric.
- PLC Twido TWDLCAA40DRF Telemecanique.
- Gateway Twido TWDXAFD010 Telemecanique.

The control system architecture is shown in Figure 3.

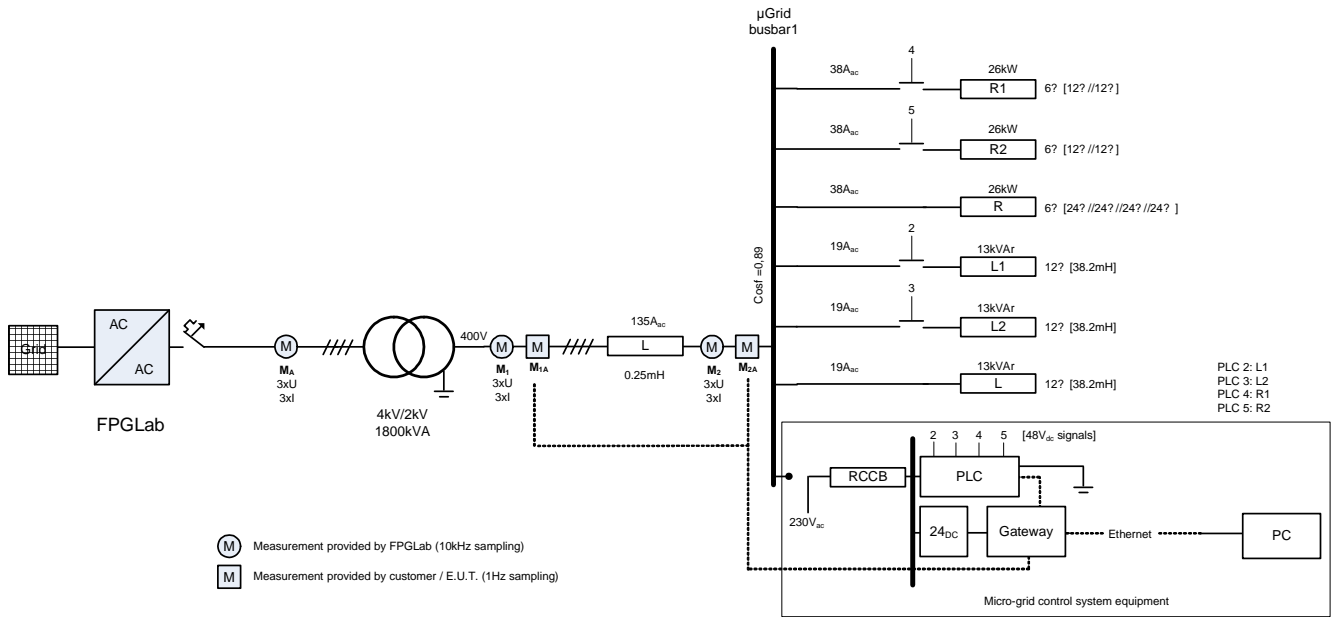

Fig. 3. Proposed control system architecture and test layout.

Power meters 710 are used to measure electrical phenomena in the low voltage (LV) micro-grid. The Twido PLC is used to perform control of the loads and energy resources involved in the micro-grid. The gateway is used to enable TCP-IP connection via Ethernet. Besides these components, some typical protection systems (circuit breakers and residual current circuit breakers, RCCBs) are used to protect the micro-grid.

All these components have been tested to analyze their suitability to be used in the control system of a LV micro-grid.

### 4. Control system validation

Validation of the components has been performed at the Flex Power Grid Lab Research Infrastructure at DNV KEMA.

The methodology used in the test is to compare the measurements obtained using the FPGLab meters (10kHz sampling) and the ones obtained using the PM710 under different power quality problems in the voltage supply. The voltage is obtained using the FPGLab programmable converter that enables to obtain an unbalanced three voltage source.

#### A. Voltage supply changes tests

One group of the tests made to validate the Power Meter 710 is related to voltage phenomena, that is, supply changes. This test consists of the measurement of a voltage sag in the three phases. At the beginning the phase voltage is 230Vrms, it then drops to 210Vrms for 10s, goes up to 230Vrms for 5s, then drops back to 210 Vrms for 10s and at the end recovers to 230 Vrms.

In Figures 4 and 5 the RMS values obtained in the test are presented.

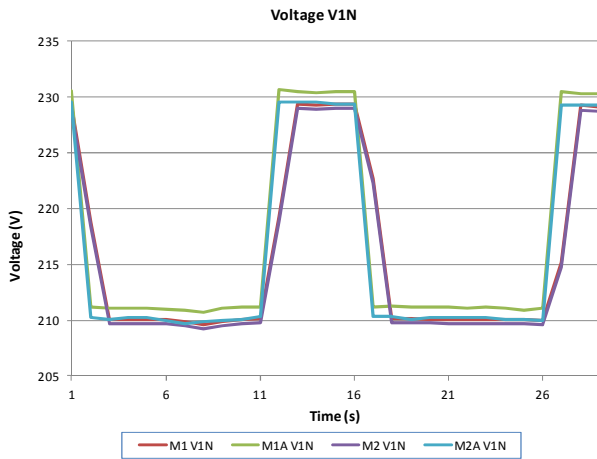

Fig. 4. RMS voltage V1N values in meters at 400 V.

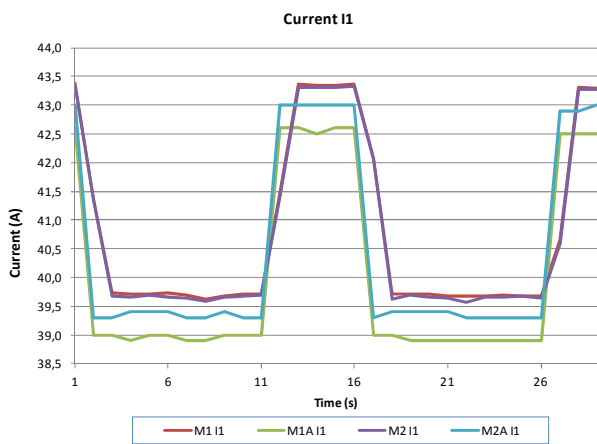

Fig. 5. RMS current I1 values in meters at 400 V.

### B. Load voltages changes test

Another similar group of tests that has been carried out with the Power Meter 710, is the changes in voltage due to changes in the load.

The test consists of the measurement of a voltage sag in the three phases due to the connection of different loads. At the beginning the Base load ( $6\Omega$  of balanced resistors per phase and  $12\Omega$  at 50Hz of balanced inductors per phase) is connected. After 5s step 1 is connected (a further  $6\Omega$  of balanced resistors per phase and  $12\Omega$  at 50Hz of balanced inductors per phase, in parallel). After 5s step 2 is connected (again a further  $6\Omega$  of balanced resistors per phase and  $12\Omega$  at 50Hz of balanced inductors per phase, in parallel).

The results of these two group of tests are acceptable. The Power Meter 710 is, therefore, suitable to characterize sags, swells and long interruptions in the voltage supply.

### C. Harmonic distortion test

A group of tests of harmonic distortion has also been executed. Results are shown in Figure 6-8.

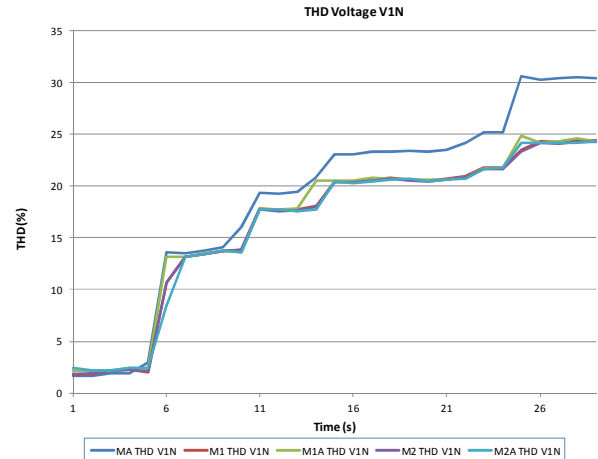

Fig. 6. THD voltage V1N values in meters at 400 V.

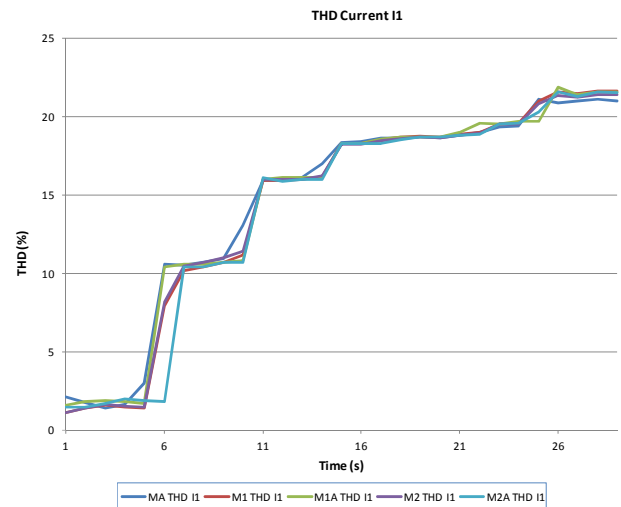

Fig. 7. THD current I1 values in meters at 400 V.

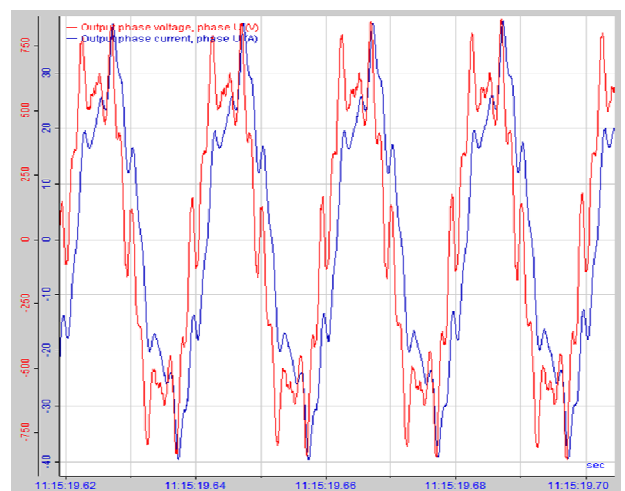

Fig. 8. Waveform during harmonic distortion in voltage MA V1N.

The RMS and THD measurement values in both the FPGLab power meters and the meters under test are similar, so the test results are acceptable. The conclusion is that the Power Meter 710 is suitable to characterize total harmonic distortion in the supply voltage, but cannot distinguish between individual harmonics.

#### D. Frequency changes test

A group of tests of frequency changes has also been done. These tests show that the Power Meter 710 is suitable to characterize changes in the frequency in the voltage supply.

#### E. Noise test

The Power Meter 710 has been tested with noise in voltage supply. The test consists of the measurement of the presence of noise in the voltage supply.

Figures 9 and 10 show the results of these tests.

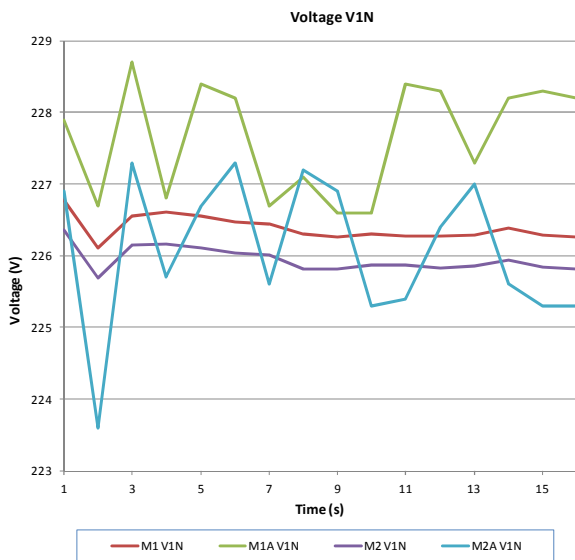

Fig. 9. RMS voltage V1N values in meters at 400 V.

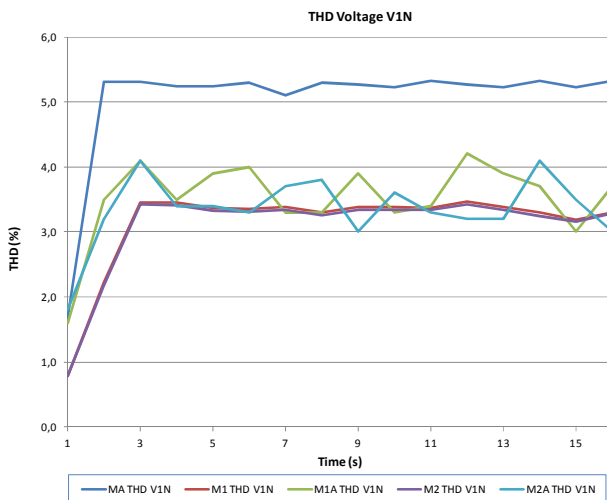

Fig. 10. THD voltage V1N values in analyzed meters.

The RMS and THD values are similar for both FPGLab and meters under test, so the test results are acceptable. The RMS values in voltages obtained using the Power Meter 710 present stronger variations. The Power Meter 710 is suitable to characterize noise in the supply voltage, but with limitations.

#### E. Transients test

A test of transients has been prepared too. The test consists of the measurement of transients in the voltage supply. RCCBs, the common means of protection used in several countries against leakage current [12], are also tested under these condition because RCCBs would be common installed in the micro-grid components and control system.

A large number of tests have been performed. Figure 11 shows the most significant results.

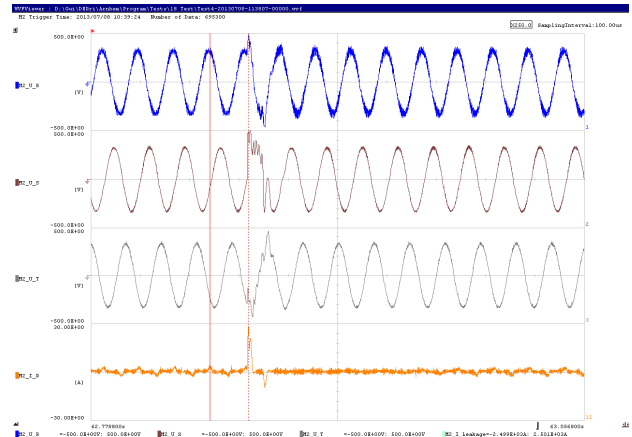

Fig. 11. Current I1 waveform as a response of a perturbation in the voltage supply. 3 computers as load.

The conclusions of these tests are that the RCCBs have not tripped during any of the applied transient tests (RCCB tripping functionality has been verified separately to exclude malfunctioning of the RCCB unit under test as reason for not tripping). As far as it has been tested, RCCBs do not trip in facilities formed by only 3 computers. It is important to mention that in larger and more complex facilities, RCCBs could lead to nuisance tripping due to a reaction of the system load characteristic to induced voltage transients.

As a conclusion of the test performed it has been identified that in order to obtain more detailed information of the system, and perform a correct control it is necessary to install a complementary meter devoted to real time characteristics at a specific electrical point of interest within the system. ION 7650 is proposed. One PM710 will be installed in each of the individual equipment to measure the energy flow.

## 5. Conclusions

After analyzing the test results the following conclusions can be made:

- The Power Meter 710 is deemed suitable for measuring the electrical phenomena in a LV micro-grid, at least in the first stage. It has been identified that in order to obtain more detailed information of the system, it is necessary to install a complementary meter devoted to real time characteristics at a specific electrical point of interest within the system.

- The selected sampling period is 1s. The magnitudes obtained are given in RMS and THD values of voltages and currents.
- The PLC ,Twidol TWDLCAA40DRF, is suitable to perform control (connection and disconnection) of the loads and the energy resources involved in the micro-grid.
- For TCP-IP connection the gateway TWDXAFD010 is required, as used during the testing.
- The typical Spanish protection systems (circuit breakers and residual current circuit breakers (RCCBs)) have been found to be suitable for protection of the micro-grid system. In particular, voltage transients must be taken into account when using RCCBs in circuits feeding electronic equipment, such as PCs, as they might lead to nuisance trips or alternatively to reduced protection levels.

## Acknowledgement

This research work has been made possible with the support of the Programa de Apoyo a la Investigación y Desarrollo (PAID-06-12) de la Universitat Politècnica de València (Spain) and the Flex Power Grid Lab Research Infrastructure at DNV KEMA, the Netherlands under the European FP7 project - DERri (grant agreement 228449).

## References

[1] Michael Angelo Pedrasa, Ted Spooner, "A Survey of Techniques Used to Control Microgrid Generation and Storage during Island Operation".

- [2] Farid Katiraei, Reza Iravani, Nikos Hatziargyriou, Aris Dimeas, "Microgrids Management, Control and Operation Aspects of Microgrids", IEEE power & energy magazine.
- [3] Jong-Yul Kim, Jin-Hong Jeon, Seul-Ki Kim, Changhee Cho, June Ho Park, Hak-Man Kim, Kee-Young Nam, "Cooperative Control Strategy of Energy Storage System and Microsources for Stabilizing the Microgrid during Islanded Operation", IEEE Transactions on Industrial Electronics, VOL. 25, NO. 12, December 2010.
- [4] H. Nikkhajoei, R. H. Lasseter, Fellow, "Microgrid Protection", IEEE PES General Meeting, 24-28 June 2007, Tampa, FL.
- [5] Ahmad Razani Haron, Azah Mohamed, Hussain Shareef "A Review on Protection Schemes and Coordination Techniques in Microgrid System", Journal of Applied Sciences 12(2): 101-112, 2012.
- [6] Hannu Jaako Laaksonen, "Protection Principles for Future Microgrids", IEEE Transactions on Power Electronics, VOL 25, NO 12, December 2010.
- [7] Robert H. Lasseter, Paolo Piagi, "Microgrid: A Conceptual Solution", PESC'04 Aachen, Germany 20-25 June 2004.
- [8] Benjamin Kroposki, Robert Lasseter, Toshifumi Ise, Satoshi Morozunim Stavros Papathanassiou, Nikos Hatziargyriou, "Making Microgrids Work", IEEE power & energy magazine.
- [9] J. A. P. Lopes, C. L. Moreira, and A. G. Madureira, "Defining control strategies for microgrids islanded operation," IEEE Trans. Power Syst., vol. 21, no. 2, pp. 916-924, May 2006.
- [10] P. Paolo and L. Robert, "Autonomous control of microgrids," IEEE Power Eng. Soc. Meeting, Montreal, Canada, Jun. 18-22, 2006.
- [11] F. Katiraei, R. Iravani, N. Hatziargyriou, and A. Dimeas, "Microgrids management-controls and operation aspects of microgrids," IEEE Power Energy, vol. 6, no. 3, pp. 54-65, May/June. 2008.
- [12] C. Roldán-Porta, G. Escrivá-Escrivá, F. J. Cárcel-Carrasco, C. Roldán-Blay. Nuisance Tripping of Residual Current Circuit Breakers. A Practical Case. Electric power system research 106 (2014) 180-187.