

## Long-Term Optimal Generation Expansion Planning considering CO<sub>2</sub> Reduction Policies and Mechanisms

Yuqian Song<sup>1</sup>, Jin Zhong<sup>1</sup> and Math H. J. Bollen<sup>2</sup>

<sup>1</sup>Department of Electrical and Electronic Engineering  
The University of Hong Kong  
Hong Kong SAR

Phone number: +852 28578422, e-mails: yqsong@eee.hku.hk, and jzhong@eee.hku.hk

<sup>2</sup> Electric Power Engineering Group  
Luleå University of Technology  
Skellefteå, Sweden  
E-mail: math.bollen@ltu.se

**Abstract** In a deregulated power system, a well-designed market mechanism could promote the optimal distribution of resources within the system. As one of the major sources of CO<sub>2</sub> emissions, power industry can be seriously impacted by carbon emission-related policies and regulations. This paper considers three widely promoted emission policies, using a long-term power system planning model to obtain the optimal generation expansion plan for twenty years. By analysing and comparing system investment schemes under different emission-related mechanisms, the processes of how these policies influence generation investment are revealed. The effectiveness of these policies is compared to determine the optimal carbon emission mechanism.

### Key words

Cap and trade mechanism, carbon taxes, carbon emission, feed-in tariff, generation expansion planning.

### 1. Introduction

Electricity sector is considered as one of the major contributors of Green House Gas (GHG) emissions. Relevant organizations have been working on the solutions to maintain the economic development, while at the same time reducing GHG emissions, especially the CO<sub>2</sub> emission due to the combustion of fossil fuel. Simply interfering with the operation of power system might influence the economic development. Therefore, some countries have come up with a series of emission reducing mechanisms, such as Carbon Taxes, Renewable Energy Certificates (REC), Feed-In-tariff (FIT), Cap and Trade, etc. These mechanisms are the most popular and widely implemented approaches. They could encourage the investment of new renewable generation, and also affect the generation patterns of existing electricity generators. Renewable energy generation units and generators

with lower CO<sub>2</sub> emission levels may be dispatched more. In a long term, clean energy generation units are expected to generate more energy and have a higher priority to be invested in a power system than traditional heavy emission ones.

Regulators around the world have come up with all types of policies and regulations in order to limit the emission within an acceptable range. Take the achievement of the European Union as an example, the European Union is the leader in promoting carbon emission reducing mechanisms. It has been more than 15 years since the concept of national emission limits was proposed [1]. Different emission-related mechanisms were implemented in European countries, three of them, carbon taxes, feed-in tariff, and cap and trade, are particular effective and far-reaching, which will be analysed in this paper.

Carbon tax is a mechanism that supplements extra charges to the emitters due to every unit of carbon dioxide emission. It usually labels a unit price to the emitted carbon dioxide as tax and the emitters have to pay for the emission in this price. Some of the Nordic countries such as Sweden and Finland impose carbon taxes in order to encourage clean energy development.

Feed-In Tariff is the extra subsidy that offered by the regulators to the electricity that generated by clean energy and renewable energy generation units for their contribution in emission reduction, as well as an approach of compensation for the high operation and investment cost of these types of generation units. Feed-in-tariff (FIT) was promoted in Germany and Denmark resulting in a huge boost in renewable energy investment [2].

This work was partly supported by grants from the Research Grant Council of Hong Kong (Project No. HKU10/CRF/10), HKU Strategic Research Theme and the University Development Funding (Initiative on Clean Energy & Environment).

Cap and Trade allows emitters a free discharge within the limit of emission Cap that allocated by the regulator. For entities whose actual emission amounts exceed the quota, extra allowances should be purchased to cover the excess emission, otherwise, they may face serious penalties from the regulator. On the other hand, the surplus allowance from the entities whose emissions are below the cap can be sold in order to obtain extra profits. Cap and Trade mechanism has been acknowledged as one of the most effective solutions and been implemented in most of the European countries. In addition, with the development of carbon emission markets in recent years, the European Union is planning to promote a completely free trading environment of carbon emission allowances.

By applying these carbon emission mechanisms, generation schedules of generation companies are subject to more constraints than ever. In order to maximize the revenue without being charged too much for carbon dioxide emission, generation companies have taken clean energy (such as advanced combine cycle units and advances thermal units with carbon capture and storage(CCS) devices, etc.) and renewable energy (wind turbines and PV generations, etc.) as reasonable solutions to carbon emission issues. These renewable energy and clean energy generators, on the other hand, usually lead to much higher cost in investment. Hence, from generation companies' point of view, it is important to find out the optimal locations and timing for new generation investment.

Traditionally, power system generation expansions are usually made by regulators. A lot of factors should be taken into consideration when obtaining this expansion schedule, such as the capital of investment, social interest rate, transmission expansion plan and congestion issues, as well as the actual situation of the chosen locations etc. Besides, the introduction of the emission issues has made the problem even more complex. By using proper optimization techniques and method, this large-scale, long-term, non-linear and discrete problem can be solved [3].

In addition, it is also critical for the regulator to estimate the effectiveness of the policies and regulations. By comparing the emissions of each generation expansion plan under different carbon reducing mechanisms, the regulator is able to obtain a more suitable mechanism in CO<sub>2</sub> reduction, or further improve the mechanism so it will do better in reducing carbon emission as well as promoting the economy and power system development.

The rest of the paper is organized as follows: a mathematical model for a long-term generation expansion plan considering different carbon emission-related mechanisms is described in Section II. The testing system based on standard IEEE118 bus system is introduced in Section III. Case studies, including the optimal generation expansion plan and effectiveness in carbon reductions are conducted in Section

IV. Section V concludes the paper based on the result of the case studies.

## 2. Mathematical Model

The long-term generation expansion planning problem is modelled base on the optimal power flow model. In the case studies, several buses are selected as the location for installing new generation sources. A series of binary variables are used to indicate the decision of whether the generation should be invested at this bus.

### A. Base case

In the base case, no emission-related mechanisms are considered. The objective function includes generation cost and levelized cost of energy [6]. Therefore, the objective function can be mathematically written as

$$\min \sum_{y=1}^{20} \sum_{i=1}^{NG} [C(P_{Gi,y}) + (w_{i,y} \times P_{INV i} \times LCOE_{type})] \quad (1)$$

where,  $NG$  is the total number of generators in the system and  $C(P_{Gi,y})$  is the generation cost of existing generators as a function of  $P_{Gi,y}$ . Binary variable  $w_{i,y}$  is the decision variable of whether bus  $i$  should be invested at year  $y$ ,  $P_{INV i}$  is the planning expansion capacity of generation at bus  $i$ , and  $LCOE_{type}$  indicates levelized cost of energy of different types of generations. In this paper, three types of generation units, conventional thermal generation units, clean energy units and renewable energy units are discussed in the expansion plan.

The aforementioned objective is then subjected to a series of constraints including:

- 1) DC power flow constraints.
- 2) Phase angle limits.

In addition to these, a few more constraints should be taken into consideration when making a long-term power system generation expansion planning.

- 3) Output limits of generation units considering the capacity increase after investment.

$$P_{\min i} \leq P_{Gi,y} \leq w_{i,y} \times P_{INV i} + P_{\max i} \quad (2)$$

where  $P_{\min i}$  and  $P_{\max i}$  are the upper and lower limits, respectively, of generators before installing new generation capacities.

- 4) The cost of expansion should be kept on in consideration once the decision of investment is made at bus  $i$ , year  $y$ .

$$w_{i,y+1} \geq w_{i,y} \quad (3)$$

It is worth to mention that,  $LCOE_{type}$  is annual parameter and as long as the investment decision is made at certain location, the  $LCOE_{type}$  of the expanded capacity should always be taken into account in the following years.

5) There should be enough redundancy when planning for the new generation. In this paper, the base load rate of system is set at 1.6.

$$\sum_{i=1}^{NG} [w_{i,y} \times P_{INV i} + P_{max i}] \geq 1.6 \times \sum_{i=1}^{NG} P_{load i,y} \quad (4)$$

where,  $P_{load i,y}$  represents the load at bus  $i$  year  $y$ .

### B. Carbon Taxes

To include carbon taxes in the long term generation expansion problem, the item, an item that represents for the cost of paying for carbon taxes is added to the objective function, which is shown as (5).

$$\min \sum_{y=1}^{20} \sum_{i=1}^{NG} [C(P_{Gi,y}) + (w_{i,y} \times P_{INV i} \times LCOE_{type}) + Tax \times E(P_{Gi,y})] \quad (5)$$

where,  $Tax$  is the carbon taxes, and  $E(P_{Gi,y})$  is the emission as a function of generation at bus  $i$  in year  $y$ .

### C. Feed-In Tariff (FIT)

Feed-in tariff is the rate paid to renewable / clean energy generations. Generation company would like to maximize the income from feed-in tariff by building more renewable generations, and also keep on minimize the total cost on power generation and new generation investment. The objective function including feed-in tariff is shown as (6).

$$\min \sum_{y=1}^{20} \sum_{i=1}^{NG} [C(P_{Gi,y}) + (w_{i,y} \times P_{INV i} \times LCOE_{type}) - FIT_{type}(P_{Gi,y})] \quad (6)$$

where,  $FIT_{type}(P_{Gi,y})$  is the function of generators' outputs  $P_{Gi,y}$  corresponding to Feed-In Tariff of different types of generations.

### D. Cap and Trade

For power systems operated with the carbon reduction mechanism of Cap and Trade, more factors might be included in the cost function. Apart from routine generation cost and leveled cost of energy, generation companies could be charged or make revenue from power interchange or trading of emission allowances. The objective function for Cap and Trade mechanism can be expressed as (7).

$$\min \sum_{y=1}^{20} \sum_{i=1}^{NG} [C(P_{Gi,y}) + (w_{i,y} \times P_{INV i} \times LCOE_{type}) + (P_{ex y} \times \rho_{ex y}) - (Q_{al y} \times \sigma_{al y})] \quad (7)$$

where,  $P_{ex y}$  is the electricity that exchanged from the external system, and  $\rho_{ex y}$  is the price of this energy exchange.  $Q_{al y}$  and  $\sigma_{al y}$  represent for the amount of carbon emission allowances that traded with other entities and the price of these allowances, respectively. An extra constraint should be added to the model which indicates that the total emission should be within the limit of the emission cap that allocated by the regulator.

$$\sum_{i=1}^{NG} E(P_{Gi,y}) \leq Cap_y - Q_{al y} \quad (8)$$

where,  $E(P_{Gi,y})$  is the emission function of generators' output at bus  $i$  in year  $y$  and  $Cap_y$  is the emission cap that allocated by the regulator in year  $y$ .

## 3. Testing System Characterization

The IEEE 118 bus test system used to test the model is shown in Figure 1 [4]. The system includes of 54 generation units, 91 loads and 186 branches. Parameters in [5] with slightly modifications are used to configure the system. The generation mix of the testing system is presented in Table 1.

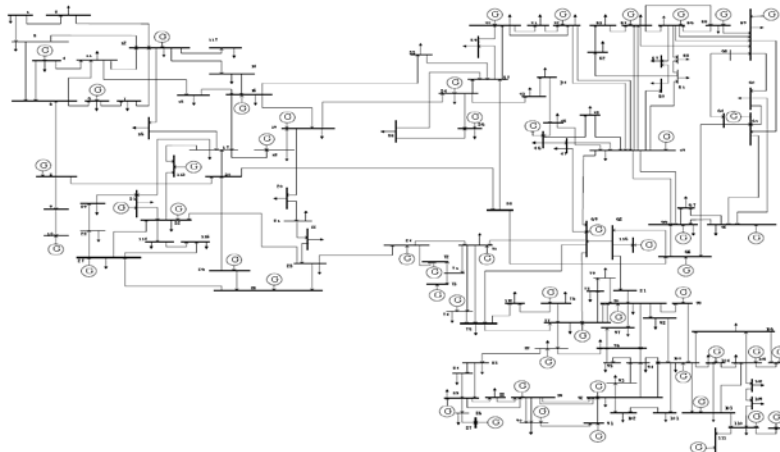

Fig. 1 Standard IEEE 118-Bus System

Table I. –Generation Mix of IEEE 118 Bus System

Unit type	Number of generators	Total generation output (MW)
Nuclear	1	500
Hydro	2	600
Coal	30	6520
Oil	10	295
Gas	11	330

#### 4. Case Study

In this testing system, three types of existing generation units are considered: coal-fired, oil-fired and gas fired generators, as well as hydro and nuclear power generations. Based on the specific conditions of the buses within the system, the units being invested in the planning model will include the types of units similar to the existing ones, as well as the clean energy generation units (such as advanced coal-fired generation with CCS) and renewable energy (such as wind turbine).

##### A. Base case

In this case, several buses are selected as the investment location of different types of generation units. Binary variable is used to indicate the decision of investment of bus *i* at year *t*. It is assumed that all the investment are made in advance, the construction is finished and the generators start serving at the beginning of each year. The base case does not consider any of the emission related policies and regulations. However, there are several factors that need to be taken into account when trying to build up this long-term planning model.

- 1) The objective function of this model is to minimize the total cost. In this case, many factors should be included, such as the capital cost of expansion and investment (personnel, construction, expansion of transmission system and installation etc.), fixed and variable operation and management cost, generation cost (including routine operation and maintenance and fuel consumption).
- 2) The annual load growth rate is fixed at 3%.
- 3) Not all the buses are included in the expansion plan. In this case, 29 buses of the entire system are chosen to install capacities.
- 4) The investment cost of energy is levelized based on the types of generation units to be invested [6].
- 5) Enough reserve capacity is assumed for the load growth during the period of generation expansion.

Optimal results of expansion planning without considering emission related policies are shown in Table II.

Table II. – Base Case Investment Plan

Bus	1	10	11	18	25	26	49	77	92
Year	13	18	19	20	17	13	16	20	14
Type	cl	ct	cl	cl	ct	ct	ct	cl	ct

where the first row represent the number of the bus to be invested, the second row is the year of investment and the third row indicates the type of the new generation units, in which ct, cl, represent for conventional thermal units and clean energy, respectively.

It can be observed that most of the invested generation units are conventional thermal units, because of their low capital cost. At year 19 and 20, there are clean energy units being invested, it is because that the system has to load rate higher than 1.6, which was constrained by (4) in the mathematical model. And the cheaper conventional thermal units may not be able to cover the growth of the load. Therefore, the clean energy is chosen to be invested. The one with highest cost, (renewable energy units) were not chosen to be invested in the base case.

##### B. Long-term Plan under Carbon Taxes

In this case, the mechanism of carbon taxes is introduced and the optimal results are shown in Table III.

Table III. –Investment Plan with Relative Low Carbon Tax

Bus	1	10	11	25	26	34	49	54
Year	13	18	13	20	15	15	14	16
Type	cl	ct	cl	ct	ct	cl	ct	ct

The result of this case is quite similar to the result of the base case, but slight changes can be observed, which is that the timing of investment on clean energy is shifted to an earlier period. As long as the cost of emission is considered in the objective function, the conventional thermal units will not be the first choice since the emission causes extra expenses. As the carbon taxes rises, the change will be more apparent, such as it is shown in Table IV.

Table IV. –Investment Plan with Relative High Carbon Tax

Bus	1	11	25	26	34	45	49
Year	1	1	20	18	18	8	19
Type	cl	cl	ct	ct	cl	re	ct
Bus	54	60	78	88			
Year	16	6	9	7			
Type	ct	re	re	re			

As the carbon tax increases, the expansion plan of the system changes significantly. Some of the investment plans were shifted forward in time, for example, bus 1 and bus 11, the generation units were invested even in the very beginning of the whole planning period. Besides, in the middle phase of the planning period, a series of renewable energy units were planned at bus 45, 60, 78 and 88, respectively. That might because that high carbon taxes have made emissions one of the dominate factors when planning for the generation expansion.

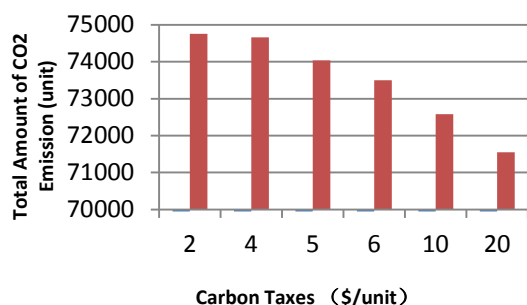

Fig I. Carbon Dioxide Emission under Different Carbon Taxes

In order to determine how much the carbon dioxide has been reduced, different carbon taxes were applied to the system and the result is shown in Figure I. The total emission drops significantly when the carbon taxes increase.

### C. Long-term Plan under FIT

Feed-In Tariff (FIT) has been acknowledged as an effective approach of promoting clean and renewable energy. However, as the levelized cost might be different in the countries that apply this mechanism, we use a percentage FIT to demonstrate its impacts on the generation expansion planning. Table V, VI and VII show the investment plan with low, medium and high FITs, respectively.

Table V. –Investment Plan with Low FIT

Bus	1	10	11	25	26	34	49	54
Year	13	14	19	20	13	19	16	17
Type	cl	ct	cl	ct	ct	cl	ct	ct

Table VI. –Investment Plan with Medium FIT

Bus	1	10	11	25	26	34	49	77	92
Year	19	15	20	17	20	13	14	20	18
Type	cl	ct	cl	ct	ct	cl	ct	cl	ct

Table VII. –Investment Plan with High FIT

Bus	1	6	10	15	25	26
Year	17	15	16	19	18	15
Type	cl	re	ct	re	ct	ct
Bus	27	32	34	49	70	74
Year	19	20	1	14	20	19
Type	re	cl	cl	ct	cl	re

It can be observed that, when FIT is relative low, the expansion plan is similar to the base case, and cheaper conventional thermal units are invested in the early phase of the planning period. Clean energy units are installed in the end of this period just to meet the incremental system load. As the percentage of FIT increases, investments on conventional thermal units are postponed and investments on clean and renewable energy are brought forward, as shown in Table VI. As the FIT keeps rising, some of the investment plans on conventional units are replaced by clean and renewable energy units, as shown in Table VII.

### D. Long-term Plan under Cap & Trade

In this case, the Cap & Trade mechanism is considered for emission. The testing system is allowed to trade emission allowances and electricity with external entities. The prices of emission allowances and exchange power are fixed since market response is not one of the issues discussed in this case. The generation expansion planning is obtained according to different emission caps allocated to the system. Table VIII shows one of the optimal solutions of investment plan when the emission cap is set at 3600 units.

Table VIII. –Investment Plan with Cap (3600)

Bus	1	6	11	15	18	25	26	27
Year	1	11	1	10	20	18	17	11
Type	cl	re	cl	re	cl	ct	ct	re
Bus	34	45	49	60	70	78	88	
Year	9	5	19	3	20	2	4	
Type	cl	re	ct	re	cl	re	re	

The result is completely different from the results of the previously discussed mechanisms. The clean and renewable energy sources are given more opportunities in the investment plan and only a few conventional thermal units were chosen to be built in the last 2 or 3 years of the entire planning period. This might be because that the trading scheme is more market-based and allows more flexibility in optimizing and distributing system resources. As long as trading mechanism is introduced, the system could slash the cost by both selling electricity or emission allowances. Investing clean and renewable energy generation allows the system achieving both emission reduction and electricity export. Hence, these types of generation units are more likely to be chosen when making decisions on investment.

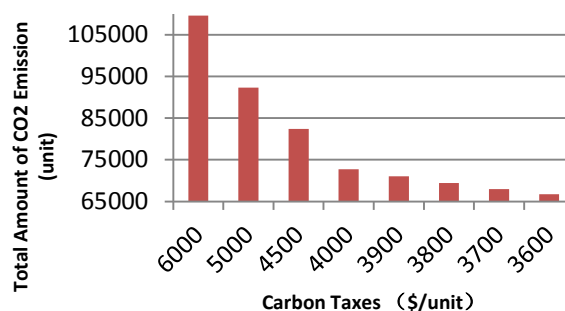

Fig II. Carbon Dioxide Emission under Different Cap

Figure II shows the system total emission under the constraints of different emission caps. Unlike the result of carbon taxes, the emission decreases even more significantly.

## 5. Conclusion

This paper has explored the impacts of different carbon mechanisms on long-term system generation expansion strategies. By optimizing the binary decision variables, a series of system investment plans are obtained considering different emission-related mechanisms. The optimization

results reveal the different processes that influence the system long-term planning. The following conclusions can be drawn:

- 1) A proper carbon tax could effectively change the generation mix and reduce the total emission in long term. However, it is a critical issue to come up with a reasonable amount of taxes. Otherwise, a 'not large enough' tax amount may not be working so well and an 'over charged' tax might be a serious strike to the entire industry.
- 2) FIT is more advanced in adjusting the generation mix of the system in a long period. Higher FIT could be very effective in promoting clean and renewable energy generation.
- 3) Cap and Trade is one of the most flexible and efficient mechanisms. It could effectively motivate the development of clean energy and renewable energy generations, as well as reducing the emission. Nonetheless, the regulator should be very careful of setting the cap. Whether a cap is reasonable will strongly affect to the effectiveness of the mechanism.

## References

- [1] The Promotion of Electricity Produced from Renewable Energy Sources in the Internal Electricity Market, Directive 2001/77/EC of the European Parliament and of the Council. (2001). [Online]. Available:<http://www.europa.eu.int/scadplus/leg/en/lvb/127035.htm>
- [2] J. A. Lesser and X. Su, "Design of an economically efficient feed-in tariff structure for renewable energy development," *Energy Pol.*, vol.36, pp. 981–990, 2008.
- [3] J. Zhu and M. Chow, "A review of emerging techniques on generation expansion planning." *Power Systems, IEEE Transactions on* 12.4 (1997): 1722-1728.
- [4] IEEE118bus\_figure, IIT Power Group, 2003, [Online], Available: <http://motor.ece.iit.edu/data/>
- [5] IEEE-118 system unit data, , IIT Power Group, 2003, [Online], Available: <http://motor.ece.iit.edu/data/>
- [6] Levelized Cost of New Generation Resources in the Annual Energy Outlook 2011 , [Online], Available: [http://www.science.smith.edu/~jcardell/Courses/EGR325/Readings/2016levelized\\_costs\\_aeo2011.pdf](http://www.science.smith.edu/~jcardell/Courses/EGR325/Readings/2016levelized_costs_aeo2011.pdf)