

## Estimation of insulation overheating in Medium Voltage and Low Voltage conductors and transformers due to stationary disturbances

I. C. Duran, Graduated Student Member, IEEE<sup>1</sup>, O. G. Duarte<sup>2</sup> and A. Pavas, Senior Member, IEEE<sup>3</sup>

<sup>1,2,3</sup> Department of Electrical Engineering  
Universidad Nacional de Colombia

Calle 44 No 45-67, Camilo Torres unit, Block B5, office 502, 100262 Bogotá (Colombia)  
Phone/Fax number: +571 3165000 10622, e-mail: [icdurant@unal.edu.co](mailto:icdurant@unal.edu.co)

**Abstract.** This paper presents a method to estimate the insulation lifetime reduction for Medium Voltage (MV) and Low Voltage (LV) conductors and transformers due to the presence of stationary power quality disturbances. Insulation aging can be accelerated by temporary increases of rms values of voltages and currents caused by stationary disturbances, i.e. harmonics. A short duration increase of rms values cannot cause a significant reduction of insulation's lifetime, but its recurrent presence during long time periods will produce a cumulative effect. Currently available models for insulation aging are employed.

### Key words

Power quality, insulation lifetime, Harmonics, Arrhenius equation, Accelerated Aging Factor.

### 1. Introduction

The constant growth of input of non-linear loads in Colombia have led to the increased of harmonic distortion, increase that deteriorates the power quality in the electrical networks. These distortions cause, among many affectations, thermal stresses that accelerate the aging in the dielectric material of the power equipment. This change in the rate is the main cause of the decrease of lifetime and premature failure of the insulation on conductors and transformers.

The Colombian Energy and Gas Regulatory Commission (CREG), by Resolution CREG 024 of 2005 have demanded to the country's electricity utilities, the installation of power quality measurement devices in substations buses and circuits headers [1]. Studies made by the Universidad Nacional de Colombia and CODENSA, have revealed that one of the major problems in power quality is the increase in harmonic distortion.

These previous results have led to the study of the impact of stationary power quality disturbances due to the entrance of non-linear loads of domiciliary and small businesses users, by the measurements in the laboratory and then with field measurements. Among the non-linear loads that impact the power quality are electronic devices (computers, televisions latest technology, chargers), fluorescent lamps, among others. In this paper a method for estimating the riskful contributions of stationary power

quality disturbances to stress the insulators is presented. The estimation of lifetime reduction is extracted from currently available procedures. These procedures are adapted to take into account the effects of currents related to the considered power quality disturbances.

### 2. Lifetime and aging in power equipment

Different studies about aging in power equipment have shown that electrical and thermal stresses are the main cause of accelerated aging, and the thermal stresses are mainly caused by the increase in current magnitudes.

The aging due to thermal stress are based on the results of the study of the Arrhenius thermal reaction theory or Arrhenius equation [2], equation that relates a specific rate of chemical reaction of the material and its temperature, as shown in Eq. (1), and followed with the research conducted by T. Dakin [3],[4] who formulated the Accelerated Aging Factor ( $F_{AA}$ ), Eq. (2), to estimate the aging factors of the dielectric material within the power equipment.

$$K_0 = A \exp \left[ \frac{-E_a}{K \times T} \right] \quad (1)$$

$$F_{AA} = \exp \left[ \left( \frac{B}{\theta_{H-R} + 273} \right) - \left( \frac{B}{\theta_H + 273} \right) \right] \quad (2)$$

Where,

$K_0$  is the reaction rate constant.

$A$  is the constant that depends in part on chemical concentrations in the reaction.

$E_a$  is the activation energy of the degradation process.

$T$  is the absolute reaction temperature in Kelvin.

$K$  is the Boltzmann constant.

$B$  is the slope of aging rate [5].

$\theta_H$  is the Hot-spot temperature in Celsius (°C).

$\theta_{H-R}$  is the maximum allowable temperature in °C (normally 110°C [5]).

The thermal stress that affects the  $F_{AA}$  depends on the currents increase. These increases in the system may be associated to different phenomena. Unbalance, asymmetry and reactive power are capable of increasing

currents over the rated values, taking the insulator's temperature to a level higher than the rated temperature. The aggregated effect of those increases will lead to lifetime reduction.

### 3. Aging in power transformers due to stationary disturbances

The main effect of stationary disturbances, in this case current harmonics on transformers is the increase in the heat dissipation in windings and top oil generated due to the power losses [6],[7]. The primary losses are the winding  $I^2R$  loss, the winding eddy-current loss which rise with the square of the load current and the square of the frequency, and stray loss from electromagnetic flux in windings, core, clamp assemblies and tanks. This increase in the heat dissipation reduces the transformer lifetime.

#### A. Hot-spot temperature rise static model

There is a first model from the IEEE std. C57.110-1998 [8] which estimates the temperature rise in the transformer due to the harmonic currents. This model applies the calculations of the Hot-spot temperature rise, Eq. (3), in power transformers in the IEEE std. C57.91-1995 [5].

$$\theta_H = \theta_A + \theta_{TO} + \theta_g \quad (3)$$

Where,

$\theta_H$  is the Hot-spot temperature rise in °C.

$\theta_A$  is the ambient temperature in °C.

$\theta_{TO}$  is the Top-oil temperature rise over the ambient in °C.

$\theta_g$  is the Hottest-spot conductor temperature rise over the top-oil in °C.

Top-oil and conductor temperature rise depends from the transformer load and manufacturer parameters, but [8] replace these variables with transformers power losses, Eq. (4), and harmonics currents spectrum.

$$P_T = P_{LL} + P_{NL} = P + P_{EC} + P_{OSL} + P_{NL} \quad (4)$$

Where,

$P_T$  is the total losses in watts (W).

$P_{LL}$  is the Load losses in W.

$P_{NL}$  is the core or No-load losses in W.

$P$  is the  $I^2R$  losses in W.

$P_{EC}$  is the winding eddy-current losses in W.

$P_{OSL}$  is the other-stray losses in W.

The transformers losses can be expressed in terms of the harmonic currents ( $I_h$ ) and the harmonic order ( $h$ )[5],[7]. These power losses are,

$$P_{EC} = P_{EC-R} \sum_{h=1}^{h_{\max}} \left( \left( \frac{I_h}{I_1} \right)^2 h^2 \right) \quad (5)$$

$$P_{OSL} = P_{OSL-R} \sum_{h=1}^{h_{\max}} \left( \left( \frac{I_h}{I_1} \right)^2 h^{0.8} \right) \quad (6)$$

$$P_{LL} = P + F_{HL} \times P_{EC} + F_{HL-OSL} \times P_{OSL} \quad (7)$$

Where,

$P_{EC-R}$  is the rated eddy-current losses in W.

$P_{OSL-R}$  is the rated other-stray losses in W.

$P_{EC-R}(pu)$  is the per-unit rated eddy-current losses.

$P_{LL-R}$  is the rated load losses in W.

$I_R$  is the fundamental current at rated conditions in amps (A).

$I_L$  is the fundamental load current in A.

And the Top-oil and conductor rise for the hot spot equation are,

$$F_{HL} = \frac{\sum_{h=1}^{h_{\max}} \left( \frac{I_h}{I_1} \right)^2 h^2}{\sum_{h=1}^{h_{\max}} \left( \frac{I_h}{I_1} \right)^2} \quad (8)$$

$$F_{HL-OSL} = \frac{\sum_{h=1}^{h_{\max}} \left( \frac{I_h}{I_1} \right)^2 h^{0.8}}{\sum_{h=1}^{h_{\max}} \left( \frac{I_h}{I_1} \right)^2} \quad (9)$$

$$\Theta_{TO} = \Theta_{TO-R} \left( \frac{P_{LL} + P_{NL}}{P_{LL-R} + P_{NL}} \right)^{0.8} \quad (10)$$

$$\Theta_g = \Theta_{g-R} \left( \frac{1 + F_{HL} \times P_{EC-R}(pu)}{1 + P_{EC-R}(pu)} \right)^{0.8} \quad (11)$$

Where,

$\Theta_{g-R}$  is the Hottest-spot conductor rise over the top-oil temperature under rated conditions in °C.

$\Theta_{TO-R}$  is the Top-oil rise over ambient temperature under rated conditions in °C.

$F_{HL}$  is the Harmonic loss factor for  $P_{EC}$ .

$F_{HL-OSL}$  is the Harmonic loss factor for  $P_{OSL}$ .

Using Eq. (10) and (11) it is possible to determine the value of temperature rise in the power transformer, but not the behavior in the time. That is why this model can be considered a static model.

#### B. Hot-spot temperature rise dynamic model

If the main objective is to estimate the behavior in the time of the hot-spot temperature rise due to currents harmonics, is necessary to seek a dynamic model that shows graphically how is this elevation increases.

For this reason in necessary to take the approach of the transformer thermal model developed in [9], where from the use of differential equations and applying the equations of temperature rise [8] can constructs two equations that represent the heat flux on the equipment and allow to build a dynamic model to estimate the behavior of the overheating in power transformers.

The differential equations for the equivalent circuit in [9] are,

$$Q_{Tot} = C_{thOil} \frac{d\Theta_{Oil}}{dt} + \frac{1}{R_{thOil}} [\Theta_{Oil} - \Theta_A]^n \quad (12)$$

$$q_w = C_{th-H} \frac{d\Theta_H}{dt} + \frac{1}{R_{th-H}} [\Theta_H - \Theta_{Oil}]^m \quad (13)$$

Where,

- $Q_{Tot}$  is the heat generated by total losses in W.
- $C_{thOil}$  is the oil thermal capacitance in Wmin/°C.
- $R_{thOil}$  is the oil thermal resistance in °C/W.
- $\Theta_{oil}$  is the top oil temperature in °C.
- $\Theta_A$  is the ambient temperature °C.
- $n$  is the exponent of loss function vs. top-oil rise [5].
- $Q_{Tot}$  is the heat generated by total losses at the hot-spot location in W.
- $C_{th-H}$  is the oil thermal capacitance at the hot-spot location in Wmin/°C.
- $R_{th-H}$  is the oil thermal resistance at the hot-spot location in °C/W.
- $\Theta_H$  is the hot-spot temperature in °C.
- $m$  is the exponent of load squared vs. winding gradient [5].
- $P_{EC-R(pu)}$  are the rated eddy current losses at the hot-spot location.
- $\tau_H$  is the winding time constant at the hot spot location in minutes (min).
- $\Delta\Theta_{H-R}$  is the rated hot spot rise over ambient in °C.

The reduction of Eq. (12) and (13) performed in [9]-[12] results on,

$$\frac{I_{pu}^2 R + 1}{R + 1} [\Delta\Theta_{Oil-R}]^n = \tau_{oil} \frac{d\Theta_{Oil}}{dt} [\Theta_{Oil} - \Theta_A]^n \quad (14)$$

$$\frac{I_{pu}^2 [1 + P_{EC-R(pu)}]}{1 + P_{EC-R(pu)}} [\Delta\Theta_{H-R}]^m = \tau_H \frac{d\Theta_H}{dt} [\Theta_H - \Theta_{Oil}]^m \quad (15)$$

Where,

- $I_{pu}$  is the load current per unit.
- $R$  is the ratio of load to no-load losses [5].
- $\tau_{oil}$  is the top oil time constant in min.
- $\Delta\Theta_{oil-R}$  is the rated top oil rise over ambient in °C.

With the studies and validations of [12]-[14] the thermal model is modified to construct a better thermal dynamic model replacing Eq. (14) and (15) on Eq. (12) and (13),

$$\frac{I_{pu}^2 R + 1}{R + 1} = \quad (16)$$

$$\frac{P_{NL} + P \sum_{h=1}^{h_{max}} I_{h-pu}^2 + P_{EC} \sum_{h=1}^{h_{max}} I_{h-pu}^2 h^2 + P_{OSL} \sum_{h=1}^{h_{max}} I_{h-pu}^2 h^{0.8}}{P_{NL-R} + P_{LL-R}} \quad (17)$$

$$\frac{I_{pu}^2 [1 + P_{EC-R(pu)}]}{1 + P_{EC-R(pu)}} = \frac{\sum_{h=1}^{h_{max}} I_{h-pu}^2 + P_{EC-R(pu)} \sum_{h=1}^{h_{max}} I_{h-pu}^2 h^2}{1 + P_{EC-R(pu)}} \quad (18)$$

$$I_{h-pu}^2 = (I_h / I_1)^2 \quad (18)$$

### C. Simulation model

The simplified diagram showed in Fig. 1 will be implemented in MATLAB/SIMULINK, and the final block diagram for the simulation is showed in Fig. 2.

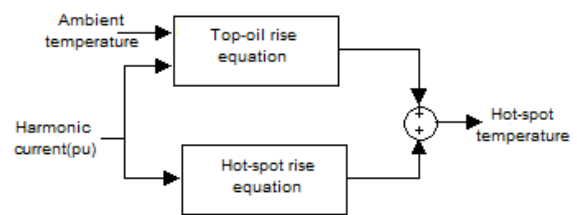

Fig. 1. Simplified diagram of the thermal dynamic model for power transformers.

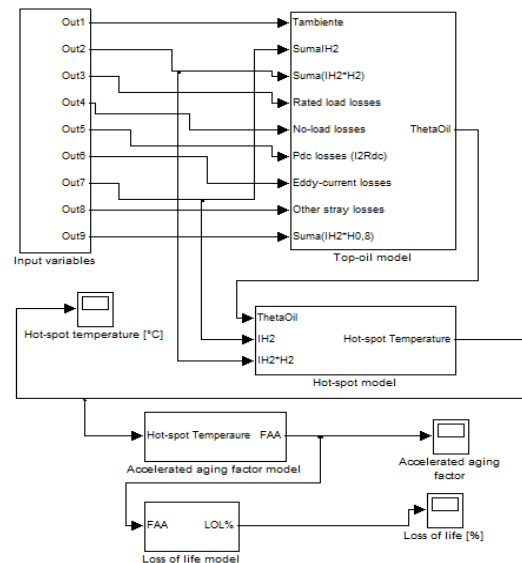

Fig. 2. MATLAB/SIMULINK simulation for the thermal dynamic model.

To show the performance of the model, we take the example of section 5.4 of [8]. This example illustrates the temperature rise calculations for a liquid-filled transformer, and the characteristics are taken from certified test report. Table I shows the characteristics for a Three-phase 2500kVA Delta-Wye transformer.

Table I. – Transformer characteristics

Parameter	Value	Unit
Primary voltage	34500	V
Secondary voltage	2400	V
Primary resistance (at 75°C)	18,207	Ω
Secondary resistance (at 75°C)	0,02491	Ω
No-load losses	5100	W
Load losses at 75°C	21941	W
Average winding rise	55	°C
Hottest-spot rise	65	°C
Top-oil time constant	114	min
Winding time constant	7	min
Exponent $m$ (for ONAN)	0,8	
Exponent $n$ (for ONAN)	0,8	

The harmonics distribution, normalized to the fundamental was supplied in Table II. The power losses for the transformer in Table III are taken from the example of section 5.4 of [8].

Table II. – Harmonic distribution

Harmonic order	Value $I_h/I_1$	Harmonic order	Value $I_h/I_1$
1	1,00	11	0,071
3	0,45	13	0,051
5	0,27	15	0,043
7	0,19	17	0,040
9	0,092	19	0,039

Table III. – Tabulated loss calculation [7]

Type of loss	Rated losses [W]	Load losses [W]	Harmonic multiplier	Corrected losses [W]
No-load	5100	5100		5100
$I^2R$	19615	14592		14592
Winding eddy	767	571	7,17	4094
Other stray	1559	1160	1,55	1798
Total losses	27041	21423		25584

Figs. 3, 4 and 5 shows the results of the simulation, taking as environment parameters, a constant ambient temperature of 25°C and sample time of 250 min.

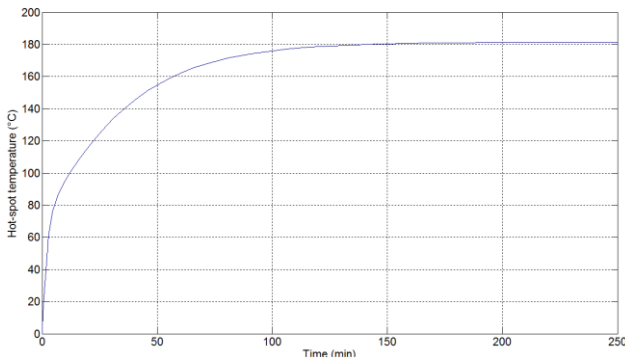

Fig. 3. Hot-spot temperature rise for 250 minutes harmonic current sample.

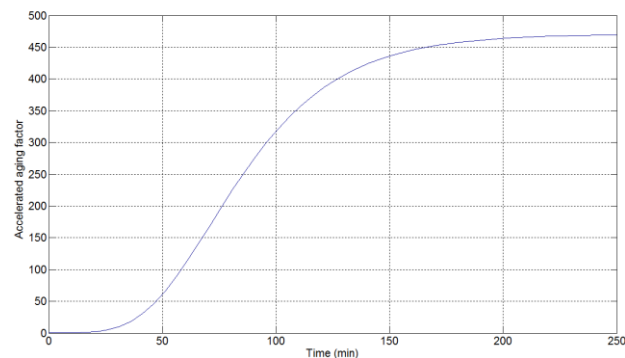

Fig. 4. Accelerated aging factor for 250 minutes harmonic current sample.

Fig. 3 shows that during the first 100min, the Hot-spot temperature increases strongly until he stabilizes after 200min. It is known that 110°C is the hottest-spot temperature for the insulation to keep the standard of loss of life in the power transformer. Which means that for the given harmonic distribution, in less than 3 hours the transformer have a strong overheating, increasing the aging factor as we observed in Fig. 4, quickly reducing the dielectric material life by 1%, and continuing to rise, up to about 6.5% after 24 hours of operation with harmonic currents.

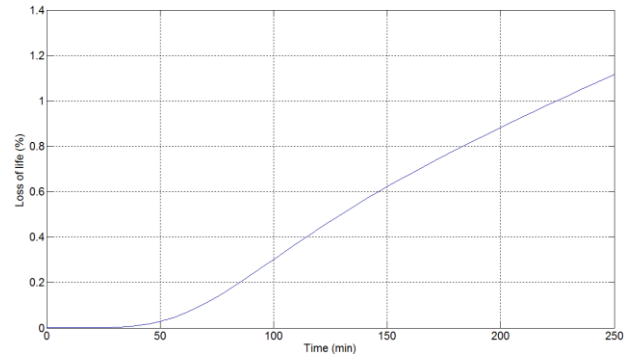

Fig. 5. Percentage of Loss of life for 250 minutes harmonic current sample.

#### 4. Aging in ML and LV conductors due to stationary disturbances

For MV and LV conductors, the major disturbances that increase the operation temperature and reduce the useful life are the current and voltage harmonics. Different articles [15]-[16] are agreed that harmonic currents are the main cause of the overheating in conductors, which degrade the dielectric material reducing his lifetime.

##### A. Cable temperature rise model

The estimated temperature rise model and reduction of life is primarily based on the  $I^2R$  power loss in the phase and neutral conductors due to the harmonic current flow [15],[16].

First, is necessary to calculate the AC resistance of the conductor with Eq. (19) and (20). This resistance is dependent of the Proximity and Skin effect losses, variables that are frequency dependent. Therefore, the ratio  $R_{ac}/R_{dc}$  is also frequency dependent.

$$R_{ac} = R_{dc}(1 + y_s + y_p) \quad (19)$$

$$R_{dc} = R_{20}[1 + \alpha_{20}(\Theta - 20)] \quad (20)$$

In [15], the ratio ( $R_{ac}/R_{dc}$ ) is expressed as,

$$\frac{R_{ac}}{R_{dc}} = 1.344 \times 10^{-15} y^4 - 3.501 \times 10^{-11} y^3 + 2.754 \times 10^{-7} y^2 - 2.544 \times 10^{-4} y + 1.0459 \quad (21)$$

$$y = \sqrt{\frac{f}{R_{dc}}} \quad (22)$$

Where,

$R_{dc}$  is the DC resistance at maximum operating temperature in  $\Omega/\text{km}$ .

$y_s$  is the skin effect.

$y_p$  is the proximity effect.

$\alpha_{20}$  is the temperature coefficient of resistance for conductor material at 20°C per Kelvin.

$\Theta$  is the maximum operating temperature in °C.

$f$  is the harmonic frequency component in hertz (Hz).

After obtaining the resistance, is possible to calculate the power losses under sinusoidal and non-sinusoidal conditions [15],[16].

$$P_{cableh} = \sum_{h=1}^{h_{max}} I_{hL1}^2 R_{achL1} + \sum_{h=1}^{h_{max}} I_{hL2}^2 R_{achL2} + \sum_{h=1}^{h_{max}} I_{hL3}^2 R_{achL3} + \sum_{h=1}^{h_{max}} I_{hLn}^2 R_{achLn} \quad (23)$$

$$P_{cablel} = 3(I_1^2 R_{acl}) \quad (24)$$

Where,

$P_{cableh}$  is the power loss in non-sinusoidal conditions in W.

$P_{cablel}$  is the power losses in sinusoidal conditions in W.

$I_{hL1}$ ,  $I_{hL2}$  and  $I_{hL3}$  are the harmonics currents for each phase in A.

$R_{ach1}$ ,  $R_{ach2}$  and  $R_{ach3}$  are the AC resistance for each frequency component and each phase in  $\Omega$ .

$I_{hLn}$  and  $R_{achn}$  are the harmonic current (in A) and the AC resistance (in  $\Omega$ ) for the neutral conductor.

Finally, with both power losses in the cable, can calculate the temperature rise due to harmonics currents and the expected lifetime. In [15] establish that this operation temperature under non-sinusoidal conditions is proportional to the power losses in p.u. (25), and from (1) can calculate the p.u. the lifetime for the cable.

$$\Theta_{ns} = \Theta_{max} \frac{P_{cableh}}{P_{cablel}} \quad (25)$$

$$Life(pu) = \exp \left[ \frac{Ea}{K} \left( \frac{1}{\Theta_{ns} + 273} - \frac{1}{\Theta_{max} + 273} \right) \right] \quad (26)$$

Where,  $\Theta_{ns}$  is the operation temperature under non-sinusoidal conditions and  $\Theta_{max}$  is the maximum operation temperature, both in  $^{\circ}C$ .

### B. Simulation model

The program for the model of overheating of ML and LV conductors was performed directly in MATLAB code because this model is static, is not time dependent. The applied flow chart is shown in Fig 6.

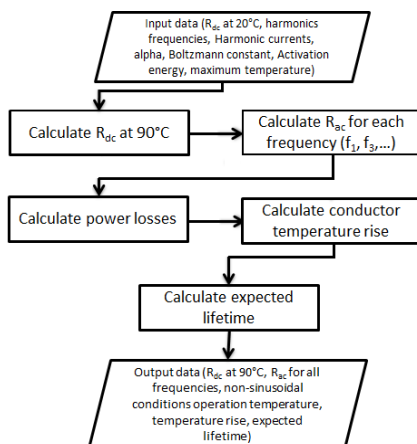

Fig. 6. Flow chart for the temperature rise program.

To show how it works, were taken as example 1km XLPE cable, where the phase harmonic spectrum is shown in Fig 7, and the neutral harmonic spectrum is shown in Fig 8, both in Amps.

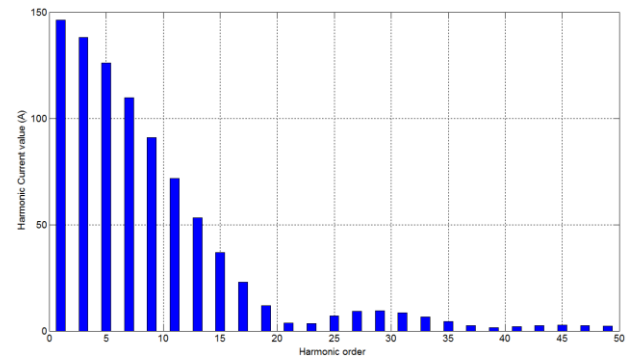

Fig. 7. Harmonic current spectrum for phase conductor.

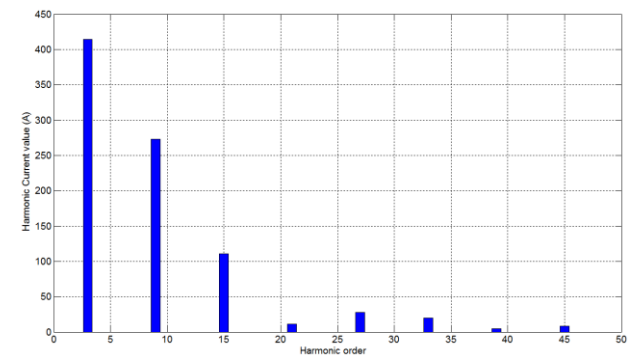

Fig. 8. Harmonic current spectrum for neutral conductor.

Using these parameters we obtain the following results. In Fig 9 we observe an unusual increase of the power losses (pu) in the zero-sequence harmonics (3<sup>rd</sup>, 9<sup>th</sup>, etc.), due to the harmonic spectrum of the neutral conductor, that's why the harmonic current to the neutral is the sum of the zero sequence harmonics components in the phase conductor. [15]. Also see that the power loss in the 3<sup>rd</sup> harmonic is three times the rated power loss in sinusoidal conditions.

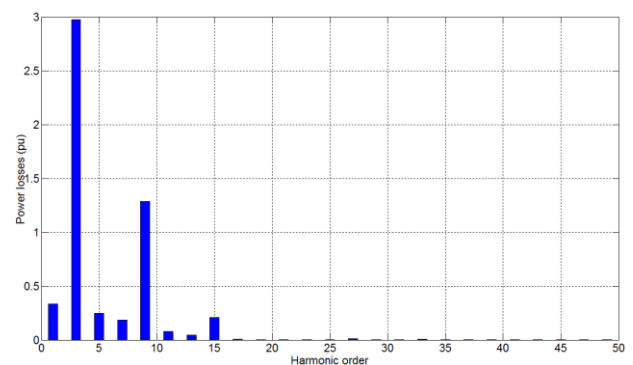

Fig. 9. Power losses for non-sinusoidal conditions.

Since in (25) the temperature rise is proportional to the non-sinusoidal power losses, Fig. 10 and Fig. 9 are similar, showing that in the Triple harmonics the cable have a more increase in the operation temperature.



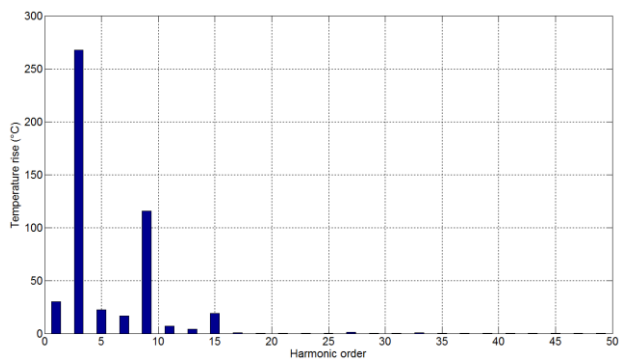

Fig. 10. Operation temperature for non-sinusoidal conditions.

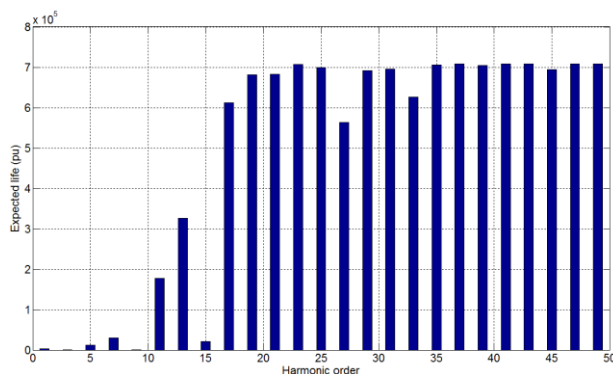

Fig. 11. Expected life (pu) for each harmonic order.

As expected, In Fig. 11 we can see that in the 3<sup>rd</sup> harmonic life expectancy is reduced to less than 5%, which indicates that the operative life of conductor reduce due to this harmonic, indifferent of the other harmonic currents. This shows that the zero-sequence harmonics are the main cause of overheating and loss of life for this case.

## 5. Conclusions

The applied dynamic model for power transformer allows to estimate the gradually loss of life over the time, and have the ability to determine the behavior of the point-to-point temperature rise, while the static model tells us only what the specific value of temperature, bringing specific percentages of loss of life but discarding possible variations within the measurement time.

With the dynamic model is possible to make different samples of harmonics currents at different times and calculate various aging factors, in order to trace an accumulated aging factor curve, better than the calculated value used in [5] and estimate a more precise loss life and remaining life due to harmonic currents for much long periods of operation.

For the simulated case, we conclude that the point of greatest temperature increase occurs in the first 200 minutes, and then stabilize the remaining time, which generates a much greater aging factor which reduces the useful life faster at that time.

On the estimation of the conductors overheating, the static model applied enables to estimate punctual behavior of the temperature rise due to each harmonic current, but it is not very accurate because cannot show the entire behavior

over the time. This suggests that to estimate the behavior over time, it is necessary to many different samples in short time intervals (*i.e.* every hour) in order to apply the cumulative aging factor [5] and establish an approximate loss of life, because use large time intervals (*i.e.* every day) exclude possible variations or peaks in losses in the time interval, which can change drastically the useful life in the conductor.

## References

- [1] G. Cajamarca, M. Romero, A. Pavas, D. Urrutia, L. Gallego, H. Torres, E. Parra. "Nueva metodología de análisis comparativo de Sags entre subestaciones de una Red de Distribución - Caso Colombiano", IV Simposio Internacional sobre Calidad de Energía, 2007, Manizales, Colombia.
- [2] K. Laidler, "The Development of the Arrhenius Equation", J. Chem. Educ., 1984, 61 (6), pp. 494.
- [3] T. Dakin, "Electrical Insulation Deterioration Treated as a Chemical Rate Phenomenon", Transactions of the American Institute of Electrical Engineers, 1948, 67, pp. 113-122.
- [4] L. Berberich, T. Dakin, "Guiding Principles in the Thermal Evaluation of Electrical Insulation Power Apparatus and Systems", Part III. Transactions of the American Institute of Electrical Engineers, 1956, 75, pp. 752-761.
- [5] IEEE STD C57.91-1995, Guide for Loading Mineral-Oil-Immersed Transformers, 1996, i.
- [6] V. Wagner, J. Balda, D. Griffith, A. McEachern, T. Barnes, D. Hartmann, D. Phileggi, A. Emmanuel, W. Horton, W. Reid, R. Ferraro, W. Jewell, "Effects of harmonics on equipment Power Delivery", IEEE Transactions on, 1993, 8, pp. 672-680.
- [7] D. Said, K. Nor, "Effects of harmonics on distribution transformers", in Proc. Power Engineering Conference, AUPEC '08. Australasian Universities, 2008, pp. 1-5.
- [8] IEEE STD C57.110-1998, Recommended Practice for Establishing Transformer Capability When Supplying Non-sinusoidal Load Currents, 1998, i.
- [9] G. Swift, T. S. Moliniski, W. Lehn, "A Fundamental Approach to Transformer Thermal Modeling-Part I: Theory and Equivalent Circuit," IEEE Trans. Power Delivery, vol. 16, No.2, Apr. 2001, pp. 171-175.
- [10] A. Elmoudi, M. Lehtonen, H. Nordman "Transformer Thermal Model Based on Thermal-Electrical Equivalent Circuit," Accepted at CMD 2006 South Korea.
- [11] A. Elmoudi, M. Lehtonen, H. Nordman, "Effect of harmonics on transformers loss of life Electrical Insulation", 2006. Conference Record of the 2006 IEEE International Symposium on, 2006, pp. 408-411.
- [12] O. Gouda, G. Amer, W. Salem, "Predicting transformer temperature rise and loss of life in the presence of harmonic load currents", Ain Shams Engineering Journal, 2012, 3, pp. 113-121.
- [13] A. Emanuel, "Estimation of loss of life of power transformers supplying non-linear loads. IEEE Trans Power Appar Syst 1985;104(3).
- [14] L. Pierrat, M. Resende, "Power transformers life expectancy under distorting power electronic loads", Proc ISIE 1996;2:578-83.
- [15] K. Patil, W. Gandhare, "Effects of harmonics in distribution systems on temperature rise and life of XLPE power cables", Power and Energy Systems (ICPS), 2011 International Conference on, 2011, pp. 1-6
- [16] J. Desmet, G. Vanalme, R. Belmans, D. Van Dommelen, "Simulation of losses in LV cables due to nonlinear loads", Power Electronics Specialists Conference, 2008. PESC 2008. IEEE, 2008, pp. 785-790.