

Renewable Energy for Desalinization using Reverse Osmosis

J. Salazar, F. Tadeo, C. Prada

Department of Systems Engineering and Automatic Control
University of Valladolid
47011 Valladolid (Spain)

Tlf: +0034 983 423566, e-mail: fernando@autom.uva.es, johanna@autom.uva.es

Abstract. This paper presents a proposal for fulfilling the energy demands of small desalination facilities in remote areas, by using a combination of renewable energies. The integrated system consists of photovoltaic modules, wind turbine, diesel generator, battery bank for energy storage and a reverse osmosis desalination unit. A central aspect is the automation of the overall system to improve reliability and ensure that the water demand is fulfilled. For this, variations in the supply of renewable energy, water demand and maintenance operations of desalination plant are taken into account using short-term predictions. The key objectives are maximise the use of renewable energies, reduce fuel dependency and engine wear and tear due to incomplete combustion.

Key words

Off-Grid Systems, Renewable Energies, Water Production, Reverse Osmosis

1. Introduction

In order to combat water scarcity, intensive desalination activities are being carried out in arid and semi-arid regions [1]. The main disadvantage of desalination plants is the intensive energy consumption [2,3]. Thus, desalination efforts now concentrate mainly on big desalination facilities, connected directly to a high-voltage electrical grid, and frequently placed near energy plants. However this is not adequate for areas, where population is sparse and infrastructures (pipelines, electrical grid) are inadequate or nonexistent. Thus, a more cost-effective solution is the local production of energy for the desalination facilities (normally in an off-grid structure, with no external transmission lines). This is especially relevant in remote areas, where power grid connections have no excess capacity enough to power a desalination plant [4]. Up to now, the usual approach is to power the plants through big diesel generators, an approach that is not sustainable from an environmental point of view, and depends on the constant supply of cheap fuel.

Therefore, we present in this paper a proposal developed with the Open-Gain project [5], of an integrated system

that combines water and electricity generation with a high degree of automation to improve reliability and make a more efficient use of energy: Reverse Osmosis (RO) emerges as a feasible desalination technology, renewable energy sources as necessary complement and decentralization of water and electricity supplies as a solution to this particular problem.

2. Reverse Osmosis Plant

The salinity of potable water recommended by the World Health Organization is 500 mg/L, but the salinity of brackish water pumped from wells is usually between 2000 and 10000 mg/L, so 90% of the salt must be removed from these feeds. A similar situation appears when treating seawater, the main difference is the higher concentration of salts. The Reverse osmosis technology is one of the methods used to desalinate seawater. The definition of Reverse Osmosis is now discussed.

Suppose a semi-permeable membrane separating two solutions of different concentrations. Osmosis is a natural process involving solvent flows across a semipermeable membrane barrier from a region of high solvent potential (low solute concentration) to an area of low solvent potential (high solute concentration), which tends to reduce the difference in concentrations between two solutions.

Reverse Osmosis (RO) is the reverse of the normal osmosis. This process uses pressure to force a solvent flowing across a semipermeable membrane from a solution of greater concentration to a solution of lesser concentration. In consequence, the solute is retaining on one side and the pure solvent pass to the other side. The direct and reverse osmosis process is showed in Figure 1.

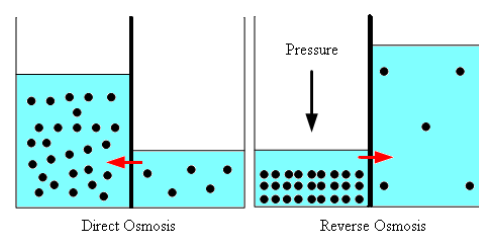

Fig. 1. The direct and reverse osmosis process

A reverse osmosis plant consists of four major components/processes: (1) pretreatment, (2) pressurization, (3) membrane separation, and (4) post-treatment stabilization. Figure 2 illustrates the basic components of a reverse osmosis system.

Pre-Treatment: The incoming feedwater is pretreated to be compatible with the membranes by removing suspended solids, adjusting the pH, and adding a threshold inhibitor to control scaling caused by constituents such as calcium sulphate.

Pressurization: The pump raises the pressure of the pretreated feedwater to an operating pressure appropriate for the membrane and the salinity of the feedwater.

Separation: The permeable membranes inhibit the passage of dissolved salts while permitting the desalinated product water to pass through. Applying feedwater to the membrane assembly results in a freshwater product stream and a concentrated brine reject stream. Because no membrane is perfect in its rejection of dissolved salts, a small percentage of salt passes through the membrane and remains in the product water.

Post-Treatment: The product water from the membrane assembly usually requires pH adjustment and degasification before being transferred to the distribution system for use as drinking water. The product passes through an aeration column in which the pH is elevated from a value of approximately 5 to a value close to 7. In many cases, this water is discharged to a storage cistern for later use.

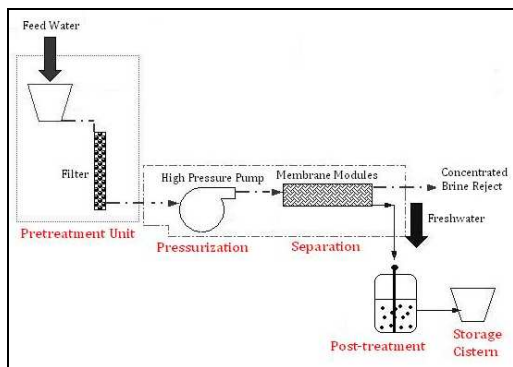

Fig. 2. Reverse Osmosis Plant

3. System proposal

A central aspect of his paper the design of an integrated system that supplies energy to small Reverse Osmosis plants through local renewable energies.

The Reverse Osmosis (RO) technology is at the present the most versatile desalination method. It is known to be a cost-effective solution to produce drinkable water from underground and sea water. Hence, RO plants need less energy, investment cost, space requirements and maintenance than other desalination processes [13], so they are being extensively implanted in fresh-water depleted areas [14].

As the target regions are arid, solar energy (Figure 3) should be the preferred energy source. Although water demand is usually higher when the solar radiance is higher, most of the day no energy is provided by the solar panels, so it must be complemented with a small wind turbine, that provides the minimal energy required when solar energy is not available. Unfortunately, the short-term unreliability of these renewable energy sources is well-known (in the presence of clouds, wind gusts, etc). Thus, as it is not recommended to shut down Reverse Osmosis plants, and the water demand must always be fulfilled, a backup system is needed. The most logical approach is to use a diesel generator to keep the RO plant running (at a minimum level) when the production of renewable energies is low.

Moreover, to fulfill the demand during those periods of no production, a big storage tank is needed, which is expensive and create losses through evaporation. Moreover, some batteries will be used, to store temporarily the extra energy generated by the renewable sources and act as a safety system.

However, big diesel generators are expensive, noisy, and not environmentally-friendly. Moreover, batteries need special care as charge/discharge cycles reduce the batteries capacity and lifetime. Thus, it is important to design a control system that schedule correctly the withdrawal of energy from the diesel engines or the batteries, which is discussed in next section.

In the past, power supplies were based on mixed DC- and AC-coupled concept (Figure 3), where PV and wind turbine are coupled on the DC-side with the battery as central component. In these systems AC-loads are supplied by battery inverters which in some cases also act as battery chargers supplied by AC-generators (e.g. Diesel). These systems are usually not extendable and show a complicated DC system design and therefore high system costs. The power that the DC coupled power generator (e.g. PV, wind turbine) can contribute to the supply of loads is limited by the rated power of the battery inverter.

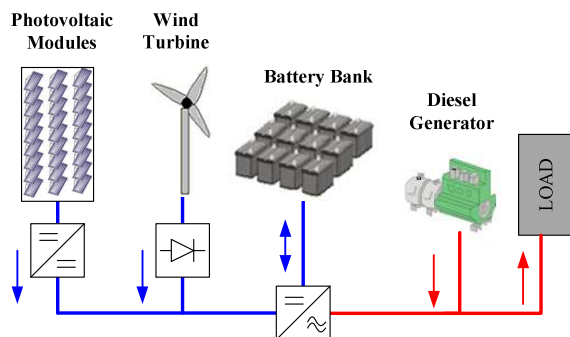

Fig. 3. Mixed DC- and AC-coupled concept

In order to overcome the above problems associated with the use of DC-Technology in off-grid systems the concept of (Pure) AC coupling (Figure 4) has been developed and introduced by University of Kassel and SMA Regelsysteme GmbH as part of the Modular System Technology [6]. "Pure AC coupled" systems

where all consumers and generators are coupled independently and equitably on a common AC-bus are currently evolving as a standard due to numerous advantages: [7,8].

- Expandability of the system to any size at any time
- Simplified design and operation of island grids
- Standardized coupling of different components (ACcoupling)
- Off-the-shelf grid components can be used
- Compatibility with existing grids
- Reduction of system costs
- Increased reliability of supply
- Off-the shelf appliances can be used

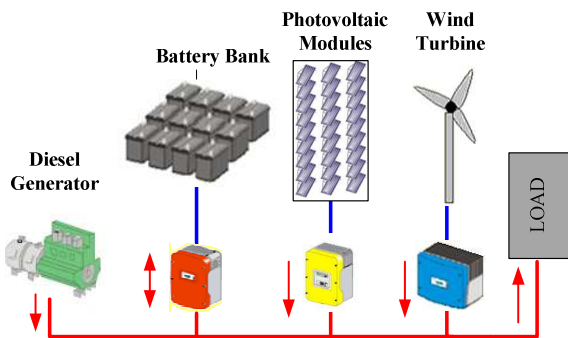

Fig. 4. Pure AC coupled concept

“Pure AC coupled” systems require a Solar, Wind and a Bidirectional Battery Inverter. The Solar Inverter changes the direct current electricity (DC) from a photovoltaic array into alternating current (AC), which is injected into the main AC bus of the system. In addition, the Solar Inverter includes a technique to get the most possible power from PV array called Maximum Power Point Tracker. The Wind Inverter converts the variable frequency voltage from wind generators into grid-conforming AC voltage.

The Bidirectional Battery Inverter functions as inverter or rectifier charger mode. In the inverter mode, it converts direct current (DC) from the battery bank into alternating current (AC) which is injected into the main AC bus of the system. When the total power generated by the PV generator and the wind turbine exceeds the load needs, it will change mode into rectifier charger to charge the battery bank.

In this “Pure AC coupled” systems, two principle operation modes are possible: The first mode of operation is island mode. The battery inverter defines the operating grid frequency and voltage. The diesel generator can either be switched off. In the second operation mode, the diesel generator defines the operating frequency and voltage. The battery inverter acts as a “grid parallel” unit, so it needs to synchronize its output voltage to the grid voltage. In both cases, wind and solar inverter operates as a “grid parallel” unit, but without any participation in the voltage or frequency regulation.

After considering all these aspects, the structure presented in Figure 9 is proposed. In order to gain real experience with the new system concept a laboratory prototype is building at Bordj Cedria in Tunisia, placed in a region of adequate wind and solar radiance patterns with the objective of producing up to 24 m3/day.

The Laboratory prototype includes a Reverse Osmosis (RO) desalination unit and a three-phase power supply system. The reverse osmosis desalination plant produces up to 24 m3/day drinking water from brackish water with salinity close to 18g/L, includes six membrane modules and a high pressure pump with 35 Bar. The power supply system comprises mainly the following components: A photovoltaic generator comprises 80 silicon mono-crystalline PV modules with a total capacity of 185 Wp, a wind turbine with 15 kW maximum power installed on a 25m height tower, a battery bank with a total capacity of 30.24 KWh and a Diesel Generator with 20KVA. To select the number of solar panels needed, and the size of the batteries and storage tanks, a central aspect is the use of simulators [15] to fine-tune the design.

Three synchronised single-phase battery inverters are interconnected to form a three phase system. In the three phase droop control algorithm, the battery inverter on Phase I is the master and the others provide an output with a phase difference of 120° and 240° respectively. All three inverters are connected to the same battery bank. The total energy of the PV and wind inverters connected to the AC-bus should not exceed the maximum input power of battery inverter 12.8kW.

The Reverse Osmosis (RO) desalination unit and photovoltaic modules built are showed in Figure 5 and 6 respectively.



Fig 5 Reverse Osmosis Plant of the demonstration facility



Fig 6 Photovoltaic Modules of the demonstration facility

4. A Voltage and Frequency Droop Control Method for Battery Inverter

Battery inverters with adequate controls offer the fundamental possibility to form low-voltage grids especially island, or micro grids, which comprise distributed energy resources and renewable energies. In order to be able to utilize all the advantages of “Pure AC coupling” in island mode a new control algorithms for battery inverters so called droop mode control [9]-[12] were developed.

In island mode, the battery inverter is able to guarantee stable power system conditions by keeping the set voltage and frequency in order to supply different consumers. High power quality is characterised by a sinusoidal voltage of a certain frequency with low harmonic distortion. It uses a battery as a buffer to balance the fluctuating energy generation by solar or wind energy and the fluctuating energy demand.

In droop mode, the battery inverter varies the grid’s frequency f depending on its current active power supply P (Figure 7), and the grid’s voltage U depending on its current reactive power supply Q (Figure 8). In case that the active power supply rises, the frequency is reduced starting from the nominal frequency f_0 . The slope of this droop is a frequency reduction Δf of -2 % of the nominal frequency or 1 Hz when reaching an active power supply of the nominal active power P_N . In case that the reactive power supply rises, the voltage is reduced starting from the nominal RMS voltage U_0 . The slope of this droop is a voltage reduction of 6 % of the nominal RMS voltage with reaching a reactive power supply of the nominal reactive power Q_N . The main principle of voltage and frequency droop control is to use the active and reactive power exchange between a generator or storage unit and the grid to control the grid voltage magnitude and frequency.

The battery inverter also tries to affect the grid’s frequency according to its battery state. If the available power on the AC bus of the system is higher than the power demanded, all battery inverters will charge their batteries and let the idle frequency slightly rise, analogous to the amount of energy stored in their batteries. The other way around, if the available power is less than the power demanded, the missing amount will be fed into the AC bus by the battery inverter, slightly reducing the AC frequency.

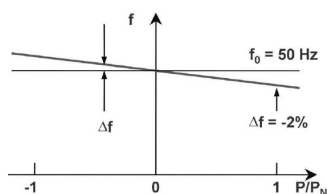

Fig. 7. Frequency-active power droop

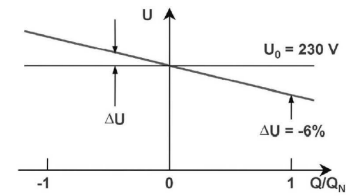

Fig. 8. Voltage-reactive power droop

The battery inverter supplies a current that is the result of the voltage difference between a reference ac voltage source, generated by droop mode, and the grid voltage across a virtual complex impedance. The reference ac voltage is synchronized with the grid, with a phase shift, depending on the difference between rated f_0 and actual grid frequency.

The droop mode with a frequency droop and a voltage droop allows to connect several battery inverters in parallel. Therewith, the droop mode enables a simple expandability of supply systems. Additionally, it is possible to distribute the share of load automatically by using different slopes for the droops.

5. Control proposal

A central aspect in the optimization of water production in remote areas using renewable energy is the use of a high degree of automation that integrates the operation of the water production facilities and the energy storage systems. This makes possible to adapt to the working conditions: variations in the supply of renewable energy and water demand and the necessary maintenance operations of desalination plant. For this reason, a control system is necessary to ensure efficient use of resources.

From a control point of view, the main difficulty found when using renewable energies for powering RO plants, is the short-term unreliability of the power supply (in the presence of clouds, wind gusts, etc). Thus, it is usually the fact that during some hours there is an excess of energy, whereas in others the provided renewable energy is not enough to supply the instantaneous demand. Then, central issues for the control system are the decision of how much energy is needed form the diesel generator and the batteries, when this energy is needed and how the reverse osmosis facility operates. The proposed control techniques (Figure 10) are based on the use of hourly predictions of energy and water demand, estimated from physical models and previous measurements, following [16, 17]. Details on the control system can be found in [18,19].

If properly handled the investment needed will be reduced (smaller batteries [capacity 2520Wh] and water storage tanks [capacity 5m³] will be needed), operation costs reduced, and the life-time of the installation will be extended (reverse osmosis plants contains delicate components like membranes).

6. Conclusion

This paper has proposed an Energy Supply System for small Reverse Osmosis plants in remote locations, where all energy needs are produced locally using mainly renewable energies. The proposed approach is devised to improve efficiency, extend the life of the components and reduce installation and operation costs. The developed algorithms are based on using hourly predictions to schedule adequately the use of the non-renewable or temporally stored energies. These predictions are based on the use of models and previous measured values of water demand, and climatic variables.

Acknowledgement

This work has been funded within the Sixth Framework Programme (Reference FP6-2004-INCO-MPC-3).

References

- [1] Postel, S. 1993. Facing water scarcity. In: State of the world, 1993. A Worldwatch Institute Report, W.W. Norton & Co., New York and London.
- [2] Fritzmann C., Löwenberg J., Wintgens T., and Melin T. (2007), State-of-the-art of reverse osmosis desalination, *Desalination*, Vol. 216, pp. 1 – 76.
- [3] Wilf, M., *The Guidebook to Membrane Desalination Technology* (Balaban Desalination Publications, L'Aquila, Italy, 2007).
- [4] Seibert U., G. Vogt, C. Brenning, R. Gebhard, and F. Holz. Autonomous, desalination system concepts for seawater and brackish water in rural areas with renewable energies. *Desalination*, 168, 29-37, 2004.
- [5] www.open-gain.org
- [6] Kleinkauf, W. et. al. (1991) Photovoltaic Power Conditioning / Inverter Technology; *10th European Photovoltaic Solar Energy Conference*; Lisbon.
- [7] Cramer, G. et al. (2004) PV System Technologies – State-of-the-Art and Trends in Decentralized electrification, *REFOCUS Journal*, p. 38 – 42.
- [8] Rothert, M. et al.(2003): The future of village electrification - More than two years of experience with AC coupled hybrid systems, *2nd European PV-Hybrid and Mini- Grid Conf.*, Kassel, Germany.
- [9] A Tuladhar, H. Jin, T. Unger and K. Mauch, Parallel operation of single inverter modules with no control interconnections, *Proc. IEEE-APEC'97 Conf.*, Feb 23-27, 1997, vol. 1, pp. 94-100
- [10] M. C. Chandorkar, D. M. Divan and R. Adapa, Control of parallel connected inverters en standalone AC supply systems, *IEEE Trans. Ind. Appl.*, vol. 29, no 1, pp. 136-143, Jan-Feb 1993
- [11] M. Hauck and H. Späth, Control of three phase inverter feeding an unbalanced load and operating in parallel with other power source, in *Proc. EPE-PEMC'02 Conf.*, Sep 9-11, 2002.
- [12] C.-C. Hua, K-A Liao, and J-R Lin, Parallel operation of inverters for distributed photovoltaic power supply system, in *Proc. IEEE – PESC'02 Conf*, Jun 23-27, 2002, pp. 1979-1983
- [13] A. Gambier, A. Krasnik, E. Badreddin, Dynamic Modeling of a Simple Reverse Osmosis Desalination Plant for Advanced Control Purposes, *Proc. of the American Control Conference*. New York, USA, 2007
- [14] Baker, R.W. (2004). Membrane Technology and Applications. *Wiley*
- [15] Syafie, S., L. Palacin, L., C. de Prada, F. Tadeo (2008). Membrane Modeling for Simulation and Control of Reverse Osmosis in Desalination Plants, *Proc. of Control 2008*, Manchester, UK.
- [16] Alvisi, S, Franchini, M., Marinelli, A. (2003). A Stochastic Model for Representing Drinking Water Demand at Residential Level, *Water Resources Management*, 17(3), 197-222.
- [17] Chaabene M., Annabi M. (1997). A dynamic model for predicting solar plant performance and optimum control, *Energy*, 22(6), 567-578.
- [18] Palacin, L., C. de Prada, F. Tadeo (2009). Operation of Desalination Plants Using Hybrid Control, *Proc. CMDTE*, Hammamet, Tunisia.
- [19] Palacin, L., F. Tadeo, J. Salazar, C. de Prada (2009) Control of Reverse Osmosis Plants using Renewable Energies, *Proc. International Conference on Control and Applications*, Cambridge, United Kingdom.

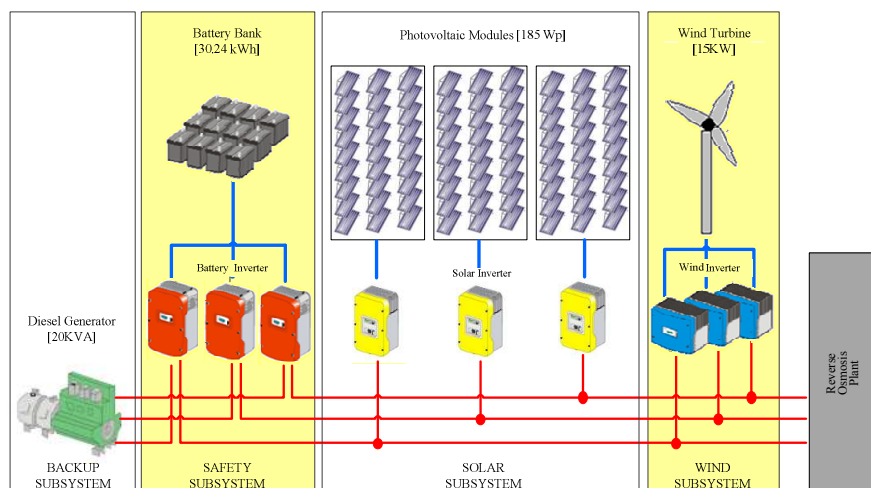

Fig. 9. Proposed Renewable Energy System.

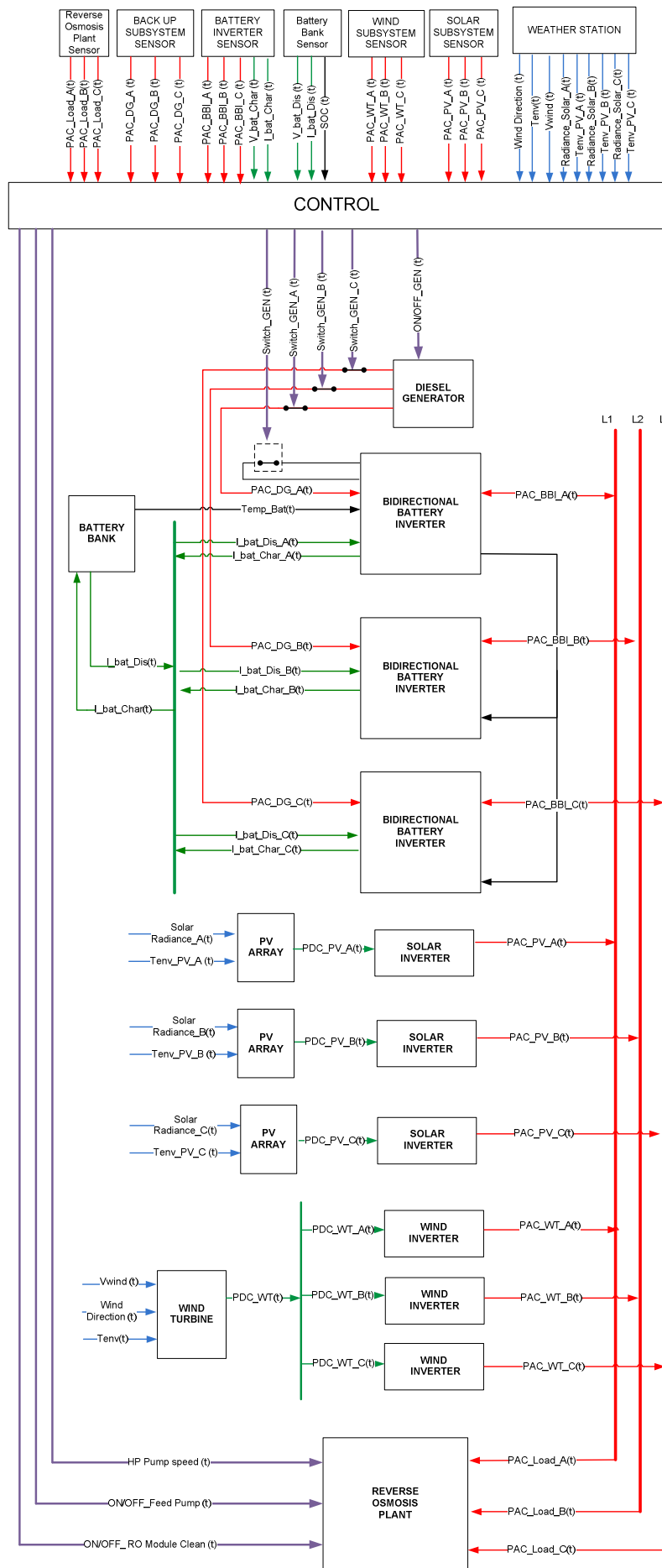

Fig. 10. High-Level Controller System Proposal