

Hybrid Technologies: Fuel Cells and Renewable Energies

J.I. San Martín ¹, I. Zamora ², J.J. San Martín ¹, V. Aperribay ¹, P. Eguía ²

Department of Electrical Engineering - University of the Basque Country

¹ Escuela Universitaria de Ingeniería Técnica Industrial de Eibar
Avda. Otaola, 29, 20600 Eibar (Spain) – e_mail: iepadij@sb.ehu.es

² Escuela Técnica Superior de Ingeniería de Bilbao
Alda. Urquijo, 48013 Bilbao (Spain) – e_mail: inmaculada.zamora@ehu.es

Abstract

Hybrid systems are characterized by containing two or more technologies of electrical generation, in order to optimize global efficiency of the processes. These systems can present different operation modalities. Also, they contemplate aspects that concern to the electrical and thermal efficiencies, as well as the polluting emissions reduction.

There is a wide range of possible configurations to conform hybrid systems, including hydrogen, renewable energies, gas cycles, vapour cycles or both. This paper presents and analyses those systems that use fuel cells, as base technology, for hybridization processes. Specifically, the cogeneration process that can be configured with PEMFC and SOFC technologies. Related to fuel cells of high temperature, SOFC, it is considered the possibility of using its exhaust gases, with later treatments, to generate hydrogen for the supply of the PEMFC technology. Finally, the hybridization processes of fuel cells with wind turbines and photovoltaic plants is presented.

Key words: Hybrid Technologies, Fuel Cells, Cogeneration, Microgrids, Renewable Energies.

1. Introduction

The progressive decrease of fossil fuels and the increase of environmental problems associated to their combustion, force to the searching of new energy alternatives. In this context, hydrogen arises as a new energetic vector that offers important advantages and drives primary power to the places where it is demanded. Hydrogen can be used by fuel cells without pollutant emissions. Besides, bigger energy efficiency can be obtained compared with any other type of combustion process. The basic options to obtain hydrogen are two:

- By means of a reformed process, starting from hydrocarbons and water vapour.
- By electrolysis, starting from water.

The hydrogen obtained by electrolysis is three to five times more expensive than the one obtained from reformed. However, electrolysis produces very pure hydrogen, that sometimes is an indispensable condition to avoid the poisoning of the anode catalyst.

In a near future, an important role is awarded to hydrogen for storing the energy from renewable sources and for other type of technologies in valley hours. From an economical point of view, wind energy is one of the most competitive of all the renewable energies, for what it could be the cheapest procedure to obtain hydrogen. Related to photovoltaic solar energy, the radiation threshold to begin the electrolytic hydrogen production is about 100 W/m². Also, the small-hydraulic energy is another renewable energy source to be considered.

Considering that fuel cells are the base hybridization technology, the most outstanding characteristics of some devices that participate in these combined systems are presented:

- PEMFCs require pure hydrogen for a correct operation. They have electric efficiencies that range from 40% to 60% and, also, they can be used for residential hot water. They present start up times about 1 minute and their work temperature oscillates in the range of 60°C to 80°C. Due to their characteristics, PEMFCs are the most appropriate technologies to be integrated with activated electrolyzers by means of renewable energy. They provide a high energy density and, compared to other models, are slighter and smaller.
- MCFCs work with high temperature, around 650°C. Their electrical efficiency is in the range of 50% to 60% and, considering cogeneration processes, they can reach 85%. Their higher temperatures allow the hybridization with absorption machines for trigeneration processes.
- SOFCs work with temperatures in the range of 750°C to 1.050 °C. Their electrical efficiency is about 50% to 60% and, considering cogeneration

process, they can reach 85%. These technologies are especially adequate for hybridization processes with gas micro-turbines, in the pressurized and atmospheric versions. Currently, they are being investigated to achieve a better global efficiency of the whole system.

2. Electrical Micro-grids

Interconnection of small modular generation sources to the low voltage distribution network establishes a new concept, the electrical micro-grid. The micro-grids can be connected to the electrical distribution network or work in an autonomous way. These micro-grids may include different technologies, such as: micro-turbines, wind mills, fuel cells, photovoltaic cells, etc., together with energy storage devices, such as: batteries, condensers, fly-wheels, etc. [1].

Some technologies, in the environment of micro-generation, have already been applied during many years, especially internal combustion machines and gas turbines. Others, such as micro-turbines, fuel cells and photovoltaic systems of low cost are acquiring remarkable repercussion. Additionally, in some cases, the installation of mini and micro hydraulic turbines has taken place.

It is believed that in near future electrical networks will incorporate a great quantity of low voltage micro-grids, interconnected by distribution and transmission systems. So, it will be necessary an appropriate connection for monitoring, control and management of each micro-grid. Besides, the different micro-grids will have to be managed properly inside the electrical system. Figure 1 shows a proposal of micro-grid that incorporates renewable power sources and fuel cells. In table 1, the different technologies that can participate in the configuration of the micro-grid are detailed, including data of power ranges, types of fuels and electrical efficiencies.

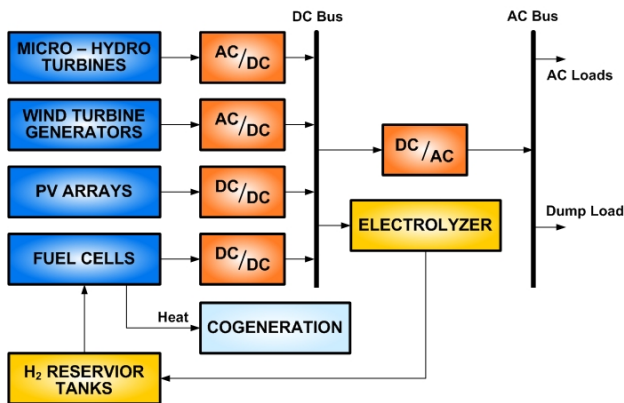

Fig 1. System configuration of the proposed multi-source alternative hybrid energy system

TABLE 1. –Technologies for electrical micro-grids

TECHNOLOGY	SIZE	FUEL	ELECTRICAL EFFICIENCY (% LHV)
COMBUSTION TURBINE COMBINED CYCLE	50 – 500 MW	Natural gas, liquid fuels	50 – 60
INDUSTRIAL COMBUSTION TURBINE	1 – 50 MW	Natural gas, liquid fuels	25 – 40
INTERNAL COMBUSTION TURBINE (RECIPROCATING ENGINE)	1 kW – 10 MW	Natural gas, diesel, oil, propane, gasoline, etc	25 – 38
MICROTURBINE	27 – 400 MW	Landfill gas, propane, natural gas, etc	22 – 30
STIRLING ENGINE	1,1 – 5 kW	Any	18 – 25
FUEL CELLS	1 kW	Natural gas, H ₂ , other H ₂ rich fuels	35 – 60
PHOTOVOLTAIC	1 W – 10 MW	Renewable	5 – 15
WIND TURBINE	0,2 kW – 5 MW	Renewable	< 40
BIOMASS	Several kW – 20 MW	Renewable	~ 20

3. Cogeneration with Fuel Cells

In cogeneration systems, the fuel quantity used to generate electrical and thermal energy is much lower than the one used in conventional systems of electrical and thermal generation separately. So, from the point of view of global efficiency, cogeneration systems (heat and electrical power) are very promising, since the sum of the efficiencies of the partial processes implies an efficient use of the primary power source. However, the applicability of these systems is limited by the heat demanded and its later use in industrial, commercial or domestic processes. This way, while a combined cycle plant can reach an efficiency of 55%, with cogeneration it could reach 90%. It is only necessary to install it next to the industrial sector and the population where water vapour or hot water is needed.

Figure 2 shows the different devices associated to fuel cells for generating of electrical and thermal power and for connection them to a micro-grid.

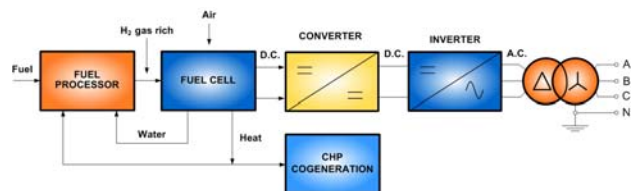

Fig 2. Fuel cell connected to a micro-grid

The simultaneous production of electrical power in fuel cells and the use of the generated heat (for example, to obtain more electrical power in a gas micro turbine, or to replace the thermal needs -heat and cold- of the installation where the fuel cell is located), allows to obtain a bigger global efficiency as it can be observed in equation (1).

$$\eta_{Global} = \frac{Q + E}{Q_o} \quad (1)$$

Where: Q is the energy used as heat; E, is the electrical power produced in the fuel cell and Q_o, the available energy in the used fuel.

This option is very common in stationary applications of fuel cells, where they generate electrical power in the range of medium or high level [2].

4. SOFC – PEMFC hybrid power system

The advantages of a system that combines the technology of fuel cells of high and low temperature are being evaluated, by means of predictive algorithms [3].

In figure 3, the block diagram corresponding to the combination of SOFC-PEMFC technologies can be seen. This model has been analysed by simulation and presents a total electrical efficiency of 61%.

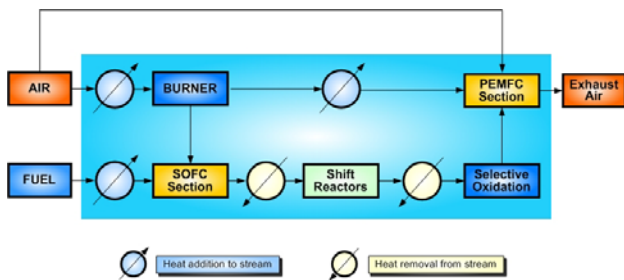

Fig.3. Scheme of SOFC – PEMFC hybrid power system

The solid oxide fuel cell (SOFC) generates electricity and exhaust gases that contain CO and H₂, not used. These gases are cooled down and introduced to the shift reactors, in which CO reacts with H₂O, producing CO₂ and H₂. After the shift reactors, the remaining traces of CO are eliminated by means of a selective catalytic reaction. This process is necessary to prevent the poisoning of the catalysts used in the PEMFC. The result is a synthesis gas, which is rich in hydrogen that later is cooled down until around 70 °C, before entering in the PEMFC. As the anode fluid of the PEMFC contains non used H₂, this is reheated to be burnt with the air flow coming from the SOFC cathode.

In order to optimize the processes, many factors are being investigated; for example, the rate of the fuel use or the increment of the cells surfaces. In this sense, it should be remembered that SOFCs have a higher price than PEMFCs, but the former are more efficient. Another process that is being studied is the design of the stages of heat recovery. To optimize the thermal efficiency of the global system, this heat should be transferred efficiently to the coldest fluids; for example, to the incoming air and the fuel, as well as to the exhaust gases coming from the PEMFC anode.

5. SOFC- Gas Micro Turbine Hybrid Power System

Figure 4 shows the block diagram of a 30 kW hybrid system, constituted by a SOFC fuel cell and a gas micro turbine.

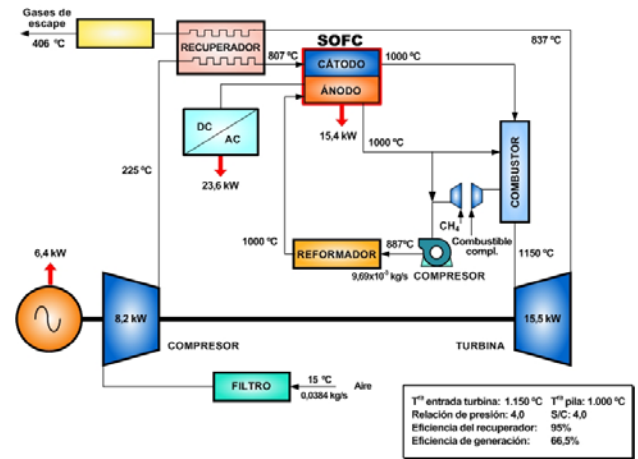

Fig.4. Scheme of SOFC – Gas Micro Turbine hybrid system

The combustion chamber of the Micro Turbine is equipped to completely oxidize the residuals included in the exhaust gases of the anode. The whole system is fed with methane at atmospheric temperature and pressure [4]. On the other hand, the compressed air warms up before entering in the SOFC cathode. The oxygen of the exit air of the cathode is used in the combustion process to burn the residual hydrogen, carbon monoxide and the existent methane. The effluents coming from the combustor expand in the turbine and, by means of a recuperator, the intake air is heated. In the reformer, methane is pre-reformed with the vapour of the anode effluents and the surplus heat coming from the SOFC.

The numeric values that appear in figure 4 show a typical example, with results based on secure design conditions. The electrical efficiency is, approximately, 63% (LHV). For this technology, efficiencies around 70% are foreseen

6. Fuel Cell – Wind Turbine – PV Hybrid Systems

Renewable energies, especially wind and solar, generate electrical power in a discontinuous way. As this power cannot always be stored or sent to the network, it finds in hydrogen an energy vector to store it. In this sense, hydrogen supplements the limitations of both energies and vice versa, the wind and photovoltaic energies can help with the high cost of producing hydrogen from the electrolysis of water.

In this scenario, renewable energies and hydrogen constitute an interesting binomial in numerous applications [5], such as generation of hydrogen in big plants for their later use in: stationary applications, transport or to feed systems connected to the electrical network. In valley hours or with the energy surplus, the wind turbine-PV systems connected to the network can supply electrical power to the electrolyser. The obtained hydrogen is stored and later on it will be used in a fuel cell. The electrical power supplied for this device will be used in the instants of low activity of the wind farm or with a limited threshold of solar radiation [6].

Another interesting application is the use of the hydrogen generated with renewable energy in the isolated autonomous systems. In these isolated systems, the demand curve does not usually adapt in great measure to the generation curve. The intermittent character of renewable energy makes necessary to store the energy for its later use in appropriate hours.

In the design of autonomous generation systems, daily energy balances are carried out based on the analysis of the necessary energy and an estimation of the produced energy. These balances use statistical data of the natural resources: solar radiation, wind speed and frequency, etc. In this supposition, the hydrogen tank has enough capacity, not only to assume the daily balance of generation and demand, but also to provide the system with an appropriate autonomy. Thus, this system is operative in periods of reduced wind generators activity.

With photovoltaic systems, the most used method to carry out this design is that named “the worst month”. The system is designed under the most restrictive conditions, that is to say, when the relationship between production and demand is the lowest. This situation usually happens in winter periods, when the solar radiation is smaller. This way, electrical supply will be guaranteed during the whole year. The differences of resources among the seasons cause these systems to be over-rated in summer and more adjusted in winter. From this point of view, the combination of wind and solar energy is usually interesting, since they are complementary resources.

The way in which hydrogen can be used for the storage of photovoltaic solar energy is shown in figure 5. This hybrid system is also known as regenerative system. During the day, the photovoltaic panels generate hydrogen and oxygen. During the night, electric power is generated by means of fuel cells. The water coming from the electrochemical reaction of the fuel cell is directed to the electrolyser.

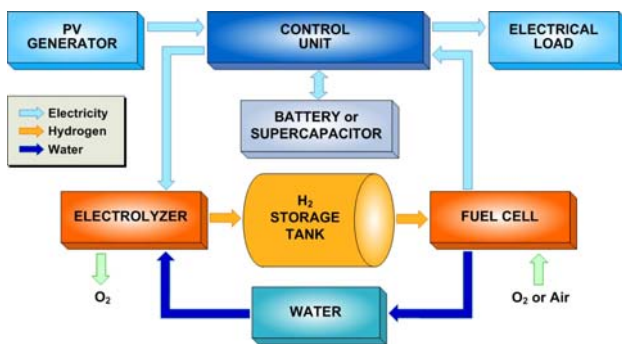

Fig.5. PV - FC hybrid system

Finally, figure 6 shows the block diagram corresponding to a hybrid system composed by “Wind Turbine-Fuel Cells-Ultra Capacitors” [7]. The system consists on a wind generator, an induction generator with a capacitors bank for the power factor correction, an ac/dc converter,

a FC/UC system, a dc/dc converter, two dc/ac inverters and a three-winding transformer that connects the system with the electrical network.

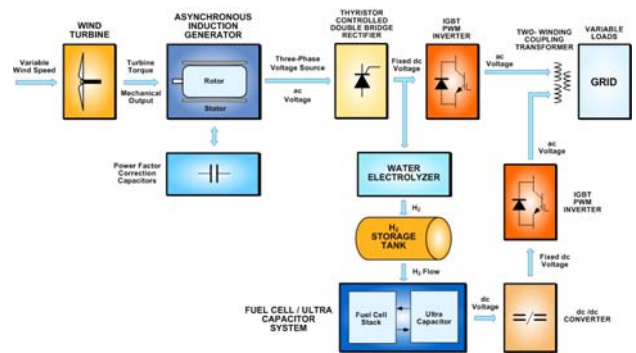

Fig.6. Wind Turbine – FC – UC hybrid system

7. Research proposals of hybrid systems with renewable energy

Renewable energies and emergent technologies, based on hydrogen as energy vector, are currently considered like an alternative to palliate the negative aspects of a highly polluting and strongly dependent energy scenario. Next, the characteristics of some research projects related with hybrid systems are presented. These projects are being developed at the European Union level.

A. RES2H2 Project

This project tries to demonstrate the viability of the “clean” hydrogen production, at industrial level. This goal can help to solve the problem of the energy storage that is usually inherent to many sources of renewable energy [8]. In this sense, the project proposes a hybrid system of hydrogen and wind energy, being the last one a source of renewable energy with significant temporary variations of energy production.

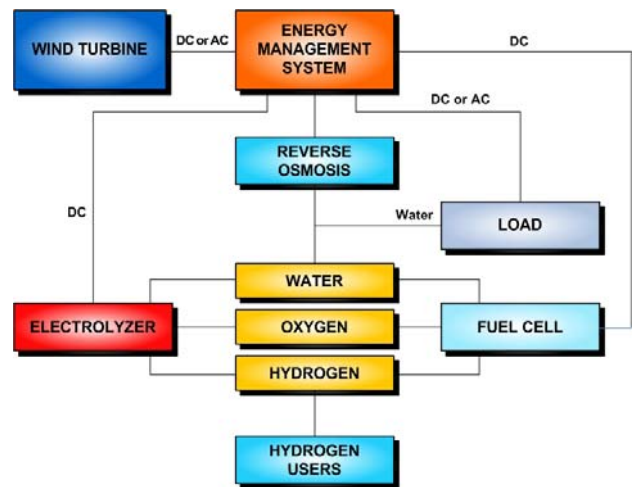

Fig 7. Wind Turbine - FC hybrid system

This system requires special attention in the design of the water electrolysis unit. On the other hand, the drinking

water is also considered as another limited resource, with a growing energy cost in the national and international environment.

In this project, two self-sufficient energy systems will be designed, built and evaluated. So that, starting from the wind energy, it will be able to generate hydrogen, electrical power and water. These type of systems could be implemented in a near future, in regions with high renewable potential, for the production and commercialization of hydrogen. Also, it would allow covering the electrical power, thermal and water demand. Figure 7 shows the general outline of the European Project RES2H2.

B. FIRST Project

This project analyzes the reliability and efficiency of the hydrogen and fuel cells use for telecommunications in remote systems, as well as the development of these generation systems [9]. The project consists on the design, installation and results analysis of two topologies: System 1 and System 2. Figures 8 and 9 show the two possible configurations that are being developed in this project.

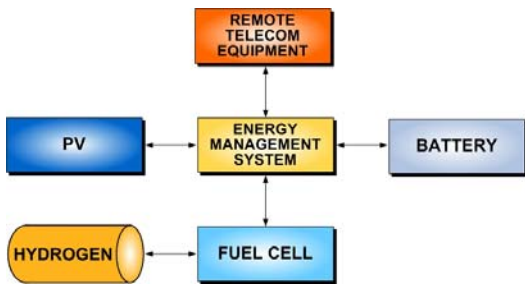

Fig 8. System 1 - FIRST Project

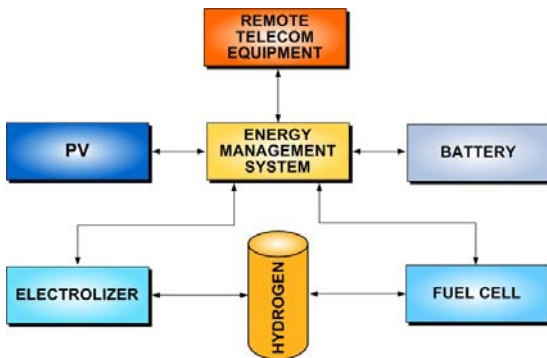

Fig 9. System 2 - FIRST Project

C. Stand-Alone Power Systems, in “La Rambla del Agua”

A high number of research works, on Stand-Alone Power Systems, are being developed in Europe. These systems supply electrical power to facilities and communities not connected to the general electrical network. These systems integrate renewable energy with the hydrogen technology. They usually replace diesel generators and

batteries for fuel cells that are fed with the hydrogen coming from an electrolyser. In this context, it is interesting to highlight that the typical efficiency of this system usually oscillates between 30 and 40%, [10].

A system of this type has been developed for “La Rambla del Agua (Granada, Spain)”. The electrical power comes from a hybrid system composed by a photovoltaic plant, a diesel generator and a battery. This conventional electrical microgrid can be seen in figure 10. Besides, a proposal of virtual reconfiguration is shown in figure 11.

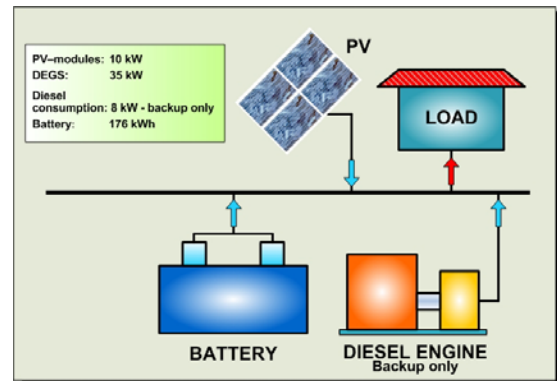

Fig 10. Conventional microgrid, “Rambla del Agua”

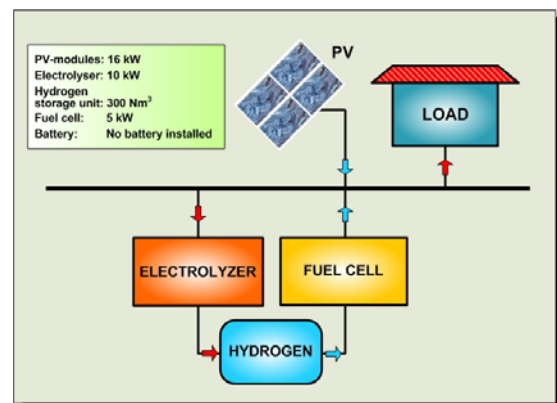

Fig 11. PV-FC hybrid system, “Rambla del Agua”

In figure 12, a comparative analysis of the energy cost is shown, for the conventional modality and the reconfigured one, in the years 2003-2005 and long term.

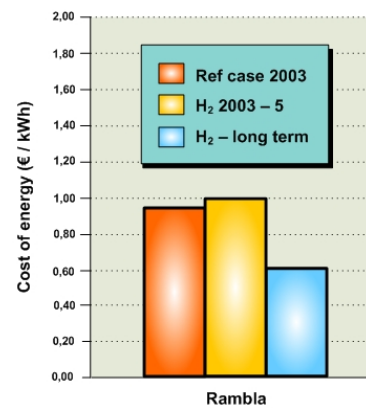

Fig 12. Comparison of the cost of energy (COE)

8. Conclusions

Improvements in the distribution system, new electronics devices and better load forecasting will mitigate, partly, the problems related to integration of renewable energies in the network. However, they will not eliminate the fluctuating nature of these renewable sources. Also, as these installations increase it will be necessary the use of storage energy systems. Among the different available options, the storage by means of hydrogen is especially attractive for its versatility. Thus, when the energy production is superior to local or programmed demand, the surplus can be used to generate hydrogen starting from water electrolysis. This hydrogen is stored and it can be used as fuel to generate electrical and thermal power, by means of stationary fuel cells.

In this sense, it should be had in mind that efficiency of the cycle “electrical power-electrolyser-hydrogen storage-fuel cell-electrical power” usually oscillates between 30% and 40%. In this supposition, the viability will appear in a scenario in which distribution systems are very dependent on intermittent power, or also, when the stable energy prices are two or three times superior to the fluctuating energy prices. On the other hand, environmental considerations and energy surpluses can advise to follow this option.

In this context, this paper has exposed the different hybrid systems that can be conformed taking fuel cells as base devices. These fuel cells are combined with cogeneration systems, wind turbines, gas micro-turbines, photovoltaic plants, small hydro, etc. These technologies are integrated in the low voltage electrical distribution system, so that they help to the maintenance of a growing electrical system, both in quantity and quality of the demanded energy.

Acknowledgements

The work presented in this paper has been developed by the research team of Project ENE2006-15700-CO2-02/CON, supported by the MEC (Spain).

References

- [1] I. Zamora, J.I. San Martín, A.J. Mazón, J.J. San Martín, V. Aperribay, J.M^a Arrieta, S. Díaz, “Desarrollo e Implantación de Microrredes Eléctricas”, Revista Energía No. 192, pp 53-61, 2006.
- [2] K. Kobayashi, M. Kawamura, T. Takahashi, Y. Nishizaka, K. Nishizaki, “PEMFC Project”, Technology Development Department, Tokyo Gas Co., Ltd.
- [3] A.L. Dicks, R.G. Fellows, C. Martin Mescal, C. Seymour, “A study of SOFC-PEM hybrid systems”, Journal of Power Sources, 2000.
- [4] S. Kimijima, N. Kasagi, “Performance evaluation of gas turbine-fuel cell hybrid microgeneration system”, Proceedings of ASME TURBO EXPO, Amsterdam, 2002.
- [5] O. Alonso, A. Vegas, F. Isorna, J. Benz, “Integración de pilas de combustible en sistemas autónomos alimentados com fuentes de energía renovables”.
- [6] K. Rajashekara, “Hybrid Fuel Cell Strategies for Clean Power Generation”, IEEE Transactions on Industry Applications, Vol. 41, No. 3, 2005.
- [7] O.C. Onar, M. Uzunoglu, M.S. Alam, “Dinamic modelling, design and simulation of a wind/fuel cell/ultracapacitor-based hybrid power generation system”, Journal of Power Sources, pp. 707-722, May 2006.
- [8] Cluster Pilot Project for the Integration of RES into European Energy Sectors using Hydrogen, Contract: ENK5-CT-2001-00536, European Commission.
- [9] FIRST Project, Contract: ERK5-CT-1999-00018. European Commission.
- [10] ALTENER Programme, Contract: 4.1030/Z/01-101-2001, European Commission.