

System Modelling and Online Optimal Management of MicroGrid with Battery Storage

Faisal A. Mohamed, Heikki N. Koivo

Control Engineering Lab, Helsinki University of Technology,

P.O. Box 5500, FIN-02015 HUT, Finland,

Phone: +35894515212, Fax: +35894515208

Email: mohamed.faisal@hut.fi, heikki.koivo@hut.fi

Abstract—This paper presents a generalized formulation to determine the optimal operating strategy and cost optimization scheme for a MicroGrid. Prior to the optimization of the microgrid itself, the system model components from some real manufactural data are constructed. The proposed cost function takes into consideration the costs of the emissions NO_x, SO₂, and CO₂ as well as the operation and maintenance costs. The microgrid considered in this paper consists of a wind turbine, a micro turbine, a diesel generator, a photovoltaic array, a fuel cell, and a battery storage. The optimization is aimed at minimizing the cost function of the system while constraining it to meet the customer demand and safety of the system.

Index Terms—microgrid, optimization, load management, Wind turbine, Photovoltaic, Diesel engine, Protone Exchange Membrane (PEM) fuel cell, Microturbine.

1. INTRODUCTION

THE need for more flexible electric systems, changing regulatory and economic scenarios, energy savings and environmental impact are providing impetus to the development of MicroGrids (MG), which are predicted to play an increasing role in the electric power system of the near future [1]. One of the important applications of the MG units, is the utilization of small-modular residential or commercial units for onsite service. The MG units can be chosen so that they satisfy the customer load demand at minimum cost all the time.

The management of the MG units require an accurate economic model to describe the operating cost taking into account the output power produced. Such a model is discrete and nonlinear in nature, hence optimization tools are needed to reduce the operating costs to a minimum level.

The increased awareness of emissions caused by power stations has led to the development of highly effective power generation with respect to the environmental requirements. Thus MGs offer an alternative that utility planners should explore in their search for the best economically and environmentally friendly solution to electric supply problems. In fact, if the MG is properly placed in a distribution network, it can reduce the power losses and defer utility investments for network enforcing. If it is not correctly applied, it can cause degradation of power quality, reliability and control of the power system, and reduce the advantages it can introduce.

Significant research has been conducted in the areas of MGs, which may have many different sizes and forms; some model architectures have been proposed in the literature such

as [2], [3]. Communication infrastructure operating between the power sources to solve the optimization problem of the fuel consumption have been proposed in [1]. A rational method of building MGs optimized for cost and subject to reliability constraints have been presented in [4].

In this paper, we rigorously study the MG components in terms of accuracy and efficiency of having a system model based on the costs of fuel, operation and maintenance, as well as the emission costs. The system model clearly has the potential to explain the costs in detail. However, developing the overall system model gives a possibility to study minimizing of the total cost of the system. Thus, it is important that the problem of minimization the cost as well as serving the load of the MG be investigated.

The second objective of this paper deals with solving the optimization problem which uses several scenarios to explore the benefits of having optimal management of the MG. The exploration is based on the minimization of running costs and is extended to cover a load demand scenario in the MG. It will be shown that by using a good system model, the optimization problem can be solved accurately and efficiently.

Our optimization method incorporates an explicit cost minimization criterion which is applied to the MG architecture. The formulation in this study to seeks the most economical generation to satisfy the load demand and constraints. The problem is decomposed into several stages, starting with building the system model which is an important stage to understand the problem. The next stage is the development of a new algorithm. The algorithm consists of determining at each iteration the optimal use of the resources available considering wind speed, temperature, and irradiation which are inputs to the model. If the produced power from the wind turbine and the photovoltaic is less than the load demand then the algorithm proceeds to the next stage here the other alternative are used according to the load amount and the cost of the resource.

2. SYSTEM MODEL

The MG architecture studied is shown in Fig 1. It consists of a group of radial feeders, which could be part of a distribution system. There is a single point of connection to the utility called Point of Common Coupling (PCC). Feeders 1 and 2 have sensitive loads which should be supplied during the events. The feeders also have the microsources consisting of

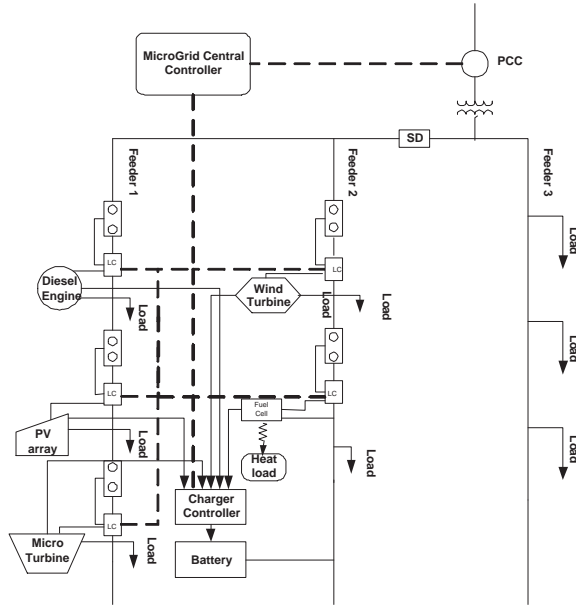

Fig. 1. MicroGrid Architecture.

a photovoltaic (PV), a wind turbine (WT), a fuel cell (FC), a microturbine (MT), a diesel generator (DG), and a battery storage. The third feeder has only traditional loads. The static switch (SD) is used to island the feeders 1 and 2 from the utility when events happenen. The fuel input is needed only for the DG, FC, and MT as the fuel for the WT and PV comes from nature. To serve the load demand and charge the battery, electrical power can be produced either directly by PV, WT, DG, MT, or FC. Each component of the MG system is modeled separately based on its characteristics and constraints. The characteristics of some equipment like wind turbines and diesel generators are available from the manufacturer. A charger controller is required to limit the depth of discharge of the battery, to limit the charging current supplied to the battery, and to prevent overcharging, while making use of the power from the other microsources when they are available.

As shown in Fig 1 , the power generated from all the microsources can be directed to serve the load and charge the battery. These relationships are expressed in general form:

$$P_i = P_{i,load} + P_{i,batt}, \forall i = 1, 2, \dots, N \quad (1)$$

where:

- P_i Output power from generator unit i ,
- $P_{i,load}$ Power from generator unit i to serve the load,
- $P_{i,batt}$ Power from generator unit i to charge the battery,
- N number of generators.

3. SYSTEM COMPONENTS

A. Wind Turbine

The following is the model used to calculate the output power generated by the wind turbine generator [?], [?] :

$$\begin{cases} P_{WT} = 0, & V < V_{ci} \\ P_{WT} = a * V^2 + b * V + c, & V_{ci} < V < V_r \\ P_{WT} = P_{WT,r}, & V > V_{co} \end{cases} \quad (2)$$

where $P_{WT,r}$, V_{ci} , and V_{co} are the rated power, cut-in and cut-out wind speed respectively. Furthermore V_r , and V are the rated, actual wind speed.

We modeled the commercial wind turbine AIR403 power curve according to equation (2), with the actual power curve obtained from the owner's manual. The parameters in model (2) are as follows: $a = 3.4$; $b = -12$; $c = 9.2$; $P_{WT,r} = 130$ watt; $V_{ci} = 3.5$ m/s; $V_{co} = 18$ m/s; $V_r = 17.5$ m/s.

B. Photovoltaic

The output power of the module can be calculated as [5]:

$$P_{PV} = P_{STC} \frac{G_{ING}}{G_{STC}} (1 + k(T_c - T_r)) \quad (3)$$

where:

- P_{PV} Output power of the module at Irradiance (G_{ING}),
- P_{STC} Module maximum power at Standard Test Condition (STC),
- G_{ING} Incident Irradiance,
- G_{STC} Irradiance at STC 1000 (W/m^2),
- k Temperature coefficient of power,
- T_c Cell temperature,
- T_r Reference temperature.

C. Diesel Generator Costs

The fuel cost of a power system can be expressed mainly as a function of its real power output and can be modeled by a quadratic polynomial [6], The total \$/h DG fuel cost $C_{DG,i}$ can be expressed as:

$$C_{DG,i} = \sum_{i=1}^N (d_i + e_i P_{DG,i} + f_i P_{DG,i}^2) \quad (4)$$

where N is the number of generators, d_i , e_i , and f_i are the coefficients of the generator, $P_{DG,i}$ is the output power (kW) of diesel generator i , $i = 1, 2, \dots, N$ are assumed to be known.

Typically, the constants d_i , e_i , and f_i are given by the manufacturer. From the data sheet [7] and equation (4) the parameters are obtained as follows: $d_1 = 0.4333$, $e_1 = 0.2333$, and $f_1 = 0.0074$.

D. Fuel Cell Cost

The efficiency of any fuel cell is the ratio between the electrical power output and the fuel input, both of which must be in the same units (W), [8]. The fuel cost for the fuel cell is calculated as:

$$C_{FC} = C_{nl} \sum_j \frac{P_j}{\eta_j} \quad (5)$$

where

- C_{nl} Natural gas price to supply the fuel cell
 P_J Electrical power produced at interval J
 η_{J} Cell efficiency at interval J

To model the technical performance of a PEM fuel cell, a typical efficiency curve is used to develop the cell efficiency as a function of the electrical power and used in equation (5) [8].

E. Microturbine Cost

The economic model is similar to the FC model. Unlike the FC, the efficiency of the MT increases with the increase of the supplied power [9].

Due to lack of detailed information, the curves of the MT are rescaled to be suitable for a unit with less than 4kW rating. These curves are used to derive the electrical efficiency as a function of the electrical power to be used in the economic model of the MT.

F. Battery Model

Batteries are electrochemical devices that store energy from other AC or DC sources for later use. The power from the battery is needed whenever the PV or/and WT are insufficient to supply the load, or when both the microsources and the main grid fail to meet the total load demand. On other hand, there will energy stored in the battery whenever the supply from the microsources exceeds the load demand.

When determining the state of charge for an energy storage device, two constraint equations must be satisfied at all times. First, because it is impossible for an energy storage device to contain negative energy, the maximum state of charge (SOC_{max}) and the minimum state of charge (SOC_{min}) of the battery are 100 % and 20 % of its Ampere Hour capacity (AH), respectively. The constraints on battery SOC:

$$SOC_{min} \leq SOC \leq SOC_{max} \quad (6)$$

Finally, in order for the system with a battery to be sustained over a long period of time, the battery SOC at the end must be greater than a given percentage of its SOC_{max} . In this study the percentage is assumed to be 90%.

4. PROPOSED OBJECTIVE FUNCTION

The purpose of this section is to describe the proposed cost function for the MG. The MG in this paper serves the isolated load demand. The design takes into account the environmental externality costs by minimizing the emissions of oxides of nitrogen (NOx), sulfur oxides (SO₂), and carbon oxides (CO₂).

The objective function is developed according to the following requirements to minimize the operating costs in \$/h of the MG:

$$CF = \sum_{i=1}^N (C_i F_i + OM_i) + \sum_{i=1}^N \sum_{j=1}^M \alpha_j (EF_{ij} P_i) \quad (7)$$

where

- C_i Fuel costs of generating unit i in \$/L for the Diesel, and \$/kW for the natural gas,
 F_i Fuel consumption rate of generator unit i in L/h for Diesel Generator, and kW/h for the FC and MT,
 F_i Fuel consumption rate of a generating unit i ,
 OM_i Operation and maintenance cost of a generating unit i in \$/h,
 α_j Externality cost of emission type j.
 EF_{ij} Emission factor of generating unit, emission type j,
 M Emission types (NOx, or CO₂, or SO₂),
 N number of generating units i .

Objective Constraints:

Power balance constraints: the total power generation must cover the total load demand hence

$$\sum_{i=1}^N P_i = P_L - P_{PV} - P_{WT} - P_{batt} \quad (8)$$

where:

- P_i The total power generation [kW],
 P_L The power demanded by the load [kW],
 P_{PV} The output power of the photovoltaic [kW],
 P_{WT} The output power of the wind turbine [kW].
 P_{batt} The output power of the battery [kW].

Generation capacity constraints: For stable operation, real power output of each generator is restricted by lower and upper limits as follows:

$$P_i^{min} \leq P_i \leq P_i^{max}, i = 1, \dots, N \quad (9)$$

where

- P_i^{min} Minimum operating power of unit i ,
 P_i^{max} Maximum operating power of unit i .

The operating and maintenance cost of the generating unit i (OM_i) is assumed to be proportional to the produced energy, where the proportional constant is (K_{OM}) [8].

$$OM_i = K_{OM} \sum_{i=1}^N P_i \quad (10)$$

The values of the K_{OM} for different generation units are as follows:

$$\begin{aligned} K_{OM}(DE) &= 0.01258 && \$/kWh \\ K_{OM}(FC) &= 0.00419 && \$/kWh \\ K_{OM}(MT) &= 0.00587 && \$/kWh. \end{aligned}$$

Externality costs and emission factors of the DE, FC, and MT used in this study are summarized in Table I [10], [11].

5. IMPLEMENTATION OF THE ALGORITHM

When designing MGs, several goals could be set, including reduction in emissions and generation cost. To achieve this, it is important to highlight all factors influencing the main goal. The following items summarize the key characteristics of the implemented strategy:

TABLE I
EXTERNALITY COSTS AND EMISSION FACTORS FOR NO_x,SO₂, AND CO₂.

Emission Type	Externality costs \$/kg	Emission factors for DE kg/MWh	Emission factors for FC kg/MWh	Emission factors for MT kg/MWh
NO _x	4.2	21.8	0.03	0.44
SO ₂	0.99	0.454	0.006	0.008
CO ₂	0.014	1.432	1.078	1.596

- Power output of WT is calculated according to equation (2) which represents the relation between the wind speed and the output power.
- Power output of PV is calculated according to equation (4) to include the effect of the temperature and the solar radiation that are different from the standard test condition.
- Since the WT and PV deliver free cost power (in terms of running as well the emission free), the output power is treated as a negative load, so the load which is the difference between the actual and microsource output can be determined if the output from PV and WT is smaller than the load demand.
- The power from the battery is needed whenever the PV and WT are insufficient to serve the load. Meanwhile the charge and discharge of the battery is monitored.
- Calculate the net load.
- Choose serving the load by other sources (FC or MT or DG) according to the objective functions.

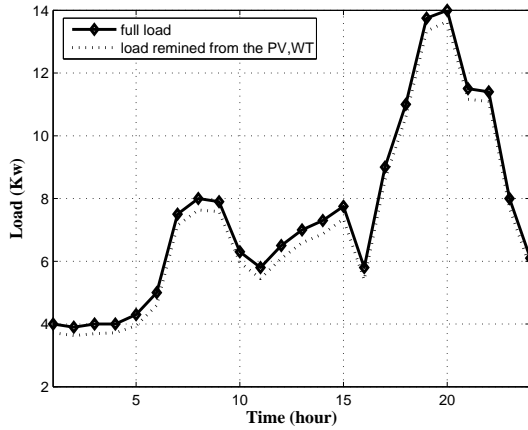

Fig. 2. Hourly load.

Aggregating the objective functions and constraints, the problem can be mathematically formulated as a constrained non-linear optimization problems as follows:

$$\min_{P_i \in \mathbb{R}^n} CF(P_i) \quad \text{subject to} \quad \begin{cases} g_i(P_i) = 0, \\ h_i(P_i) \geq 0 \end{cases} \quad (11)$$

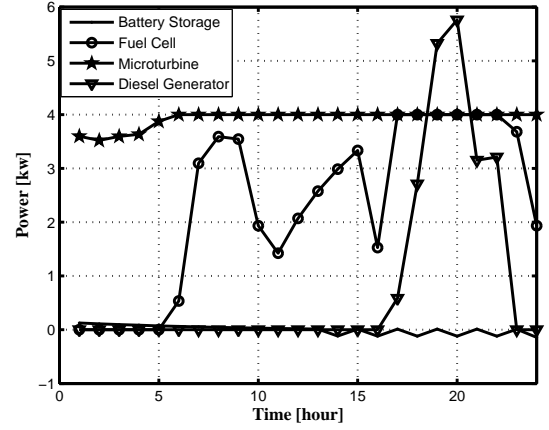

Fig. 3. The hourly power curves.

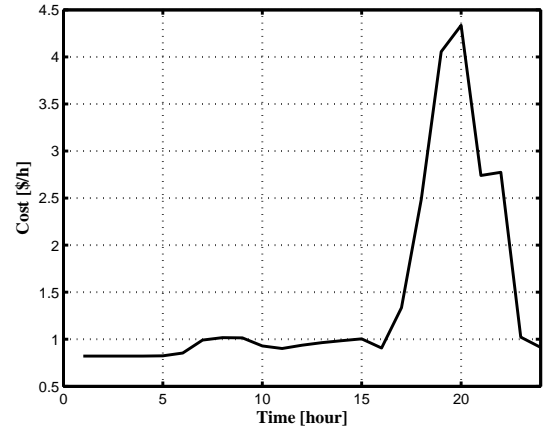

Fig. 4. Hourly total cost of the microgrid.

where:

- $P_i \in \mathbb{R}^2$ The vector of generator powers, $i = 1, \dots, N$
- $CF(P_i) \in \mathbb{R}$ The objective (cost) function which reflects the operating costs for the generator given in equation (7),
- $g_i(P_i) \in \mathbb{R}^2$ Equality constraint given in equation (8),
- $h_i(P_i) \in \mathbb{R}^2$ Inequality constraints given in equation (9).

6. RESULTS AND DISCUSSION

The optimization model described in the previous Section is applied to a time -varying load shown in Fig 2. The load demand varies between 4 kW to 14 kW. The available power

TABLE II
THE BEST SELECTION OF THE POWER GENERATORS OF THE MICROGRID

Load Demand [kw]	Fuel Cell [kw]	Microturbine [kw]	Diesel Engine [kw]	Total cost[\$/h]
3.7238	0.00	3.7238	0.00	0.8009
4.5971	0.5971	4.00	0.00	0.8074
7.1469	3.1469	4.00	0.00	0.9051
10.5923	4.00	4.00	2.5923	2.3216
13.6421	4.00	4.00	5.6421	4.1607

from the PV and the wind generators was first used. The inputs to the wind turbine model and the model of the photovoltaic were taken from real data. The load demand is served with the battery storage and at the same time we monitor the SOC and in the end of the day the battery should be full charged. From the results obtained we can see that the battery capacity was not large enough to supply the load for the whole time. The negative values of the battery power mean that the battery is in charging condition, which is added to the power demand. The algorithm then calculates the needed power to charge the battery and serve the load. The set of power curves found by the optimization algorithm are shown in Fig 3. These curves are plotted against time. It is observed from this Figure that when the load demand is low, the best choice in terms of cost is to switch off the diesel generator and start to use the output power from the microturbine. The second choice is to use the fuel cell. When the load is high at the peak time the diesel generator is switched on and use the power generated is used to serve the load. Table II together with Fig 3 confirm that the optimization technique resulted in reasonable selections. The selections for the rest of the electricity demand span are not so straightforward. The diesel engine generator is the least preferred generator because of its higher cost. It is used only when there are no other generation options available. The battery cannot serve the load as the number of the batteries is not enough to met the load demand for long enough time as it discharges faster.

7. CONCLUSION

A model to determine the optimum operation of a MG with respect to a load demand and environmental requirements is constructed. The optimization problem includes a variety of energy sources that are likely to be found in a microgrid: a fuel cell, a diesel engine, a microturbine, PV arrays, and a wind generator. Constraint functions are added to the optimization problem to reflect some of the additional considerations often found in a small-scale generation system. From the results

obtained, it is clear that the optimization procedure works very well and can give the optimal power to the generators after taking into account the cost function for each of them. Due to time-varying nature of the load demand, the variation of the battery state of charge (SOC), the system central controller need to respond to continuously changing operation conditions. The responses are effected by several variables including weather conditions, emissions operation and maintenance costs and, of course, the actual power demand.

REFERENCES

- [1] Hernandez-Aramburo, C. A., and Green, T. C., and Mugniot, N., "Fuel Consumption Minimization of a Microgrid.," *IEEE Transactions On Industry Applications*, Vol. 41, Issue. 3, May/June. 2005, p. 673-681.
- [2] Lasseter, R., "MicroGrids," *IEEE Power Engineering Society Winter Meeting, 2002.*,New York, p. 305-308.
- [3] S. Meliopoulos, "Challenges in Simulation and Design of Grids," , *Proceedings of the 2002 IEEE/PES Winter Meeting, 2002*,New York, 2002.
- [4] Shashi B. Patra, and Joydeep Mitra, and Satish J. Ranade, "Microgrid architecture: A Reliability Constraiend Approach," , *IPower Engineering Society General Meeting, IEEE* ,12-16 June 2005 Vol. 3 p. 2372 – 2377.
- [5] Lasnier, F. and Ang, T. G., "Photovoltaic Engineering Handbook" *IOP Publishing Ltd.,1990*, Adam Hilger, New York.
- [6] Wood, A. J. and Wollenberg, B. F, "Power Generation, Operation and Control," *Book.*, John Wiley & Sons, Ltd ,New York, 1996.
- [7] "[Online]. Available: www.cumminspower.com/Commercial1/Diesel/S-1215.pdf."
- [8] Azmy, A.M., and Erlich, I., "Online Optimal Management of PEM Fuel Cells Using Neural Networks," *IEEE Transactions on Power Delivery*, Vol. 29, No. 2, p. 1051-1058, April 2005.
- [9] Shampari, S., and Macchi, E, "Technical and Tariff Scenarios effect on Microturbine Trigenerative Applications" *Journal of Engineering for Gas Turbines and Power*, Vol.126, p. 581-589, JULY 2004.
- [10] Morgantown, W., "Emission rates for new DG technologies," *The Regulatory Assistance Project*, [Online]. Available, <http://www.raponline.org/ProjDocs/DREmsRul/Collfile/DGEmissionsMay2001.pdf>.
- [11] M. Pipattanasomporn, M. Willingham, and S. Rahman, "Implications of On-Site Distributed Generation for Commercial/Industrial Facilities," *IEEE Transactions on Power Systems*, Vol. 200, No. 1, p. 206-212, FEBRUARY 2005.
- [12] Mohamed, F., and H. Koivo. "System Modelling and Online Optimal Management of MicroGrid," *6th International Workshop on Large-Scale Integration of Wind Power and Transmission Networks for Offshore Wind Farms* ., 26-28 October 2006, Delft, The Netherlands.