

Real time Power Disturbance Characterization System based on Wavelet Transform and LabView platform

J. E. Ruiz, J. Aguado, F Martín, F. Muñoz, J. J. López and A. Rodríguez

Department of Electrical Engineering
E.T.S.I.I., Málaga University
Campus of El Ejido – Plaza El Ejido s/n, 29013 Málaga (Spain)
Phone/Fax number: +0034 952132707 / 1091, e-mail: jeruiz@uma.es, arodriguezg@uma.es

Abstract. This paper develops an industrial platform of low cost for characterization of the most common disturbances in a electrical system of consumption and alternative generation. The system characterizes the disturbance in frequency, time and magnitude using Multi-resolution Analysis based on Wavelet transform.

The method has a very low computational cost. Therefore it can detect and measure the disturbances in real time and make the necessary corrective actions.

Furthermore, the data record allows to analyze the evolution of the electrical network.

Key words

Data acquisition, signal processing, Disturbance Characterization, Wavelet Transform

1. Introduction

In the last decades, the necessity of having a system of monitoring of the quality electrical provision is a priority in any installation whose activity and productivity depends on the electrical energy like fundamental raw material.

But the problem is not the disturbance measurement, or the concrete correction of disturbances. The problem appears when the users (generators or consumers), those cause the disturbances in the electrical network. Then it is necessary to identify the problem, but in addition it is also necessary to characterize the disturbance, with its main features, with the aim of being able to eliminate the disturbance with the equipment designed for this purpose.

In this work the classification of disturbances is done according to the International Electrotechnic commission (IEC), in which quality definitions according to IEEE 1159 in frequency, magnitude and duration are included.

The most common disturbances in the electric network have been characterized in order and magnitude. This characterization has been made at the time of data acquisition. The aim of the analysis has been to be able of

doing the necessary corrective actions for erasing or mitigating the disturbances.

An algorithm has been designed that acquires and processes the signal at sufficient speed to be able of obtaining characteristic results of the disturbance in time, magnitude and frequency. The algorithm has been designed by means an industrial control process platform (LabView), witch satisfies the mentioned requirements. The Wavelet discrete transform (WDT) [2] has been used as mathematical basis for the development of the algorithm.

DWT has the advantage of extremely low computational cost, as its complexity is $N \cdot \log N$.

2. System analysis

The Discreet Wavelet Transform (DWT) (equation 1), has been used in the analysis of the captured signal. Five decomposition levels of high frequency have been obtained, with the aim of characterizing each disturbance in time and frequency. Multi-resolution analysis has been used for calculating the Wavelet transform (Equation 2).

$$f(t) = \sum_{j,k} \langle \Psi_{j,k}(t), f(t) \rangle \Psi_{j,k}(t) \quad (1)$$

$$\varphi(t) = \sqrt{2} \sum_n h_n \varphi(2t - n) \quad n \in Z \quad (2)$$

The system implementation has been made using as wavelet mother the Daubechies4 (db4) (Figure 1). The Wavelet db4 has represented very well the characteristic changes of a corrupt electrical signal.

The characteristic function used for obtaining the response to the frequency spectrum is shown in equation (3). It has been obtained to relate the equations (1) and (2) [1]. The coefficients of the mother wavelet 'db4' are obtained from [2].

$$f(t) = \sum_k b_{J_0,k} \varphi_{J_0,k}(t) + \sum_{j=J_0}^{J-1} \sum_k c_{j,k} \Psi_{j,k}(t) \quad (3)$$

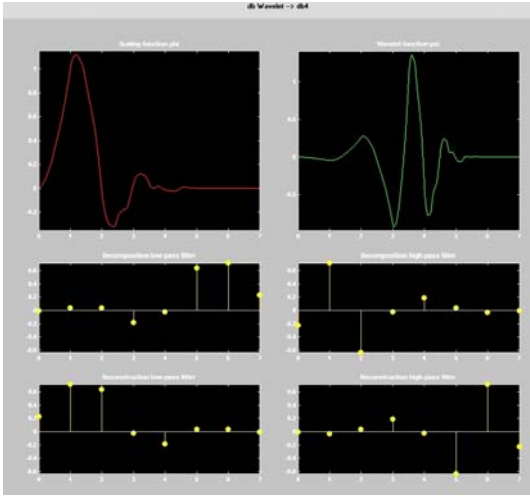

Fig. 1. Ψ , ϕ Functions and filters for the family 'db 4'

A. Software development

The system of data acquisition and processing fulfils the main premise of an online system. The time necessary for data capture is greater than the time of processing. Furthermore, the low computational cost that presents the AMR, which optimizes the 5 levels decomposition, makes a calculation of wavelet coefficients up to 3.2kHz. This represents a sampling frequency of 6.4kHz by channel (Nyquist-Shannon theorem). Considering that the actual acquisition has been made by A/D multiplexed converter, the acquisition configuration card frequency is 19.2kHz. (52 μ s for cycle of scan).

The computational cost and system acquisition time is represented in the scheme of figure 2.

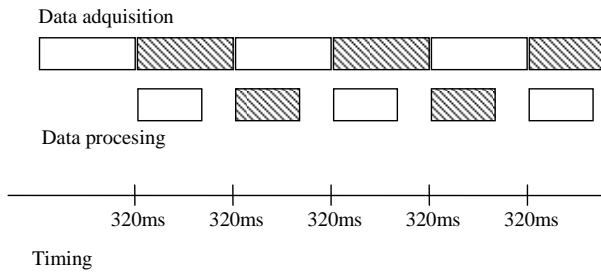

Fig. 2. Data acquisition and processing time

B. Data processing

Once the 2048 samples block per channel has been obtained, data are organized in a 4-samples sliding data window for the db4 calculation. (See figure 3). In the obtained 3-dimensions matrix the number of channel corresponds to the row, the 4 columns correspond to the sliding window, and the depth of the matrix, no greater of 2048 samples, are to the different windows created from the acquired sample block.

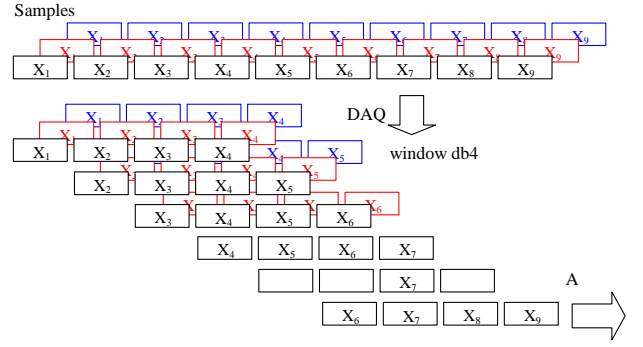

Fig. 3. Making a window wavelet

C. Wavelet Coefficients calculation

In order to obtain the coefficients of the detail signal, an operation of convolution followed of decimation by 2 is made of the previous level broad function. This operation is made on each one of the blocks shown in figure (3).

The algorithm for obtaining of the Wavelet coefficients at the different frequencies is obtained from equations (4) and (5).

$$b_{j,k} = \sum_{2k+n} h_n \cdot b_{j+1,2k+n} = \sum_l h_{l-2k} \cdot b_{j+1,l} \quad (4)$$

$$l = 2k + n$$

$$c_{j,k} = \sum_{2k+n} g_n \cdot b_{j+1,2k+n} = \sum_l g_{l-2k} \cdot b_{j+1,l} \quad (5)$$

$$l = 2k + n$$

The rows are separated and each window is multiplied by the vector 'g' or 'h' for the convolution operation (coefficients of details or broad function). This operation repeats so many times as depth of the matrix.

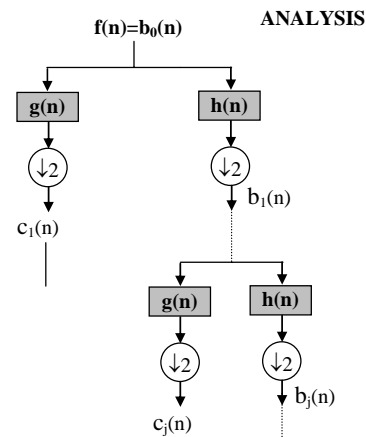

Fig. 4. Mallat Algorithm

The odd coefficients of the matrix are erased for decimation. The rest of coefficients decrease the vector dimension to the half.

In figure 4 it can be seen a graphic representation of the obtained coefficients after operations of convolution and decimation for different decomposition levels.

An example of this program in LabView platform is described in the figure 5 where the low computational cost of AMR can be seen.

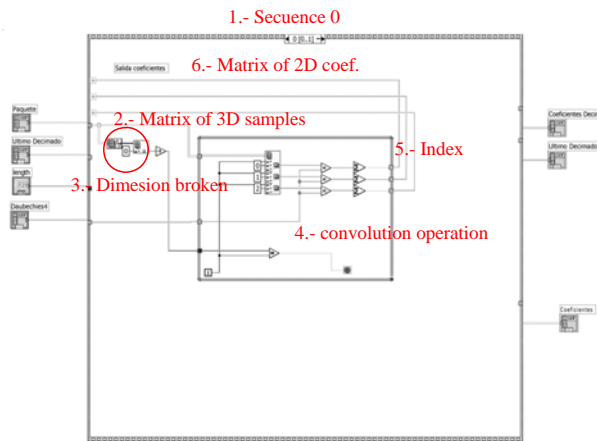

Fig. 5. Convolution subrutines

D. Disturbances detection

The high frequency detail coefficients of the decomposition appear when there exist some discontinuities in the analyzed waveform. Therefore, the detail components must be zero, except when a discontinuity in the function appears. A software block that detects these possible discontinuities of the signal has been implemented. This block analyzes the high and medium frequency coefficients according to the disturbance that can exist and witch previously has been simulated.

Evidently, in a real case like ours, where the input signal is directly captured from the electrical network, the coefficients wavelet are very low but not exactly zero, and these will be different of this value according to the signal quality.

The user can define their detection criteria in order to modify the set point, witch are initially adapted to the norm IEEE 1159.

E. User interface

The user interface has been designed for showing a full information, in order to control the disturbance set points and data record. A main screen has been designed with the purpose of having all controls accessible and all the captured signals analyzed by means of graphs and sliding control buttons.

Figure 6 shows the application main window.

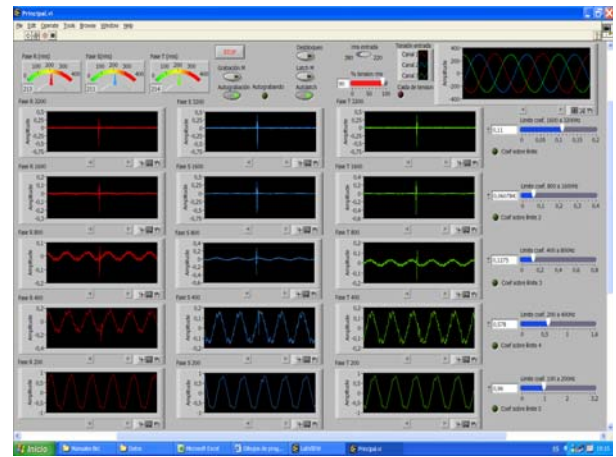

Fig. 6. Application main window

F. Hardware system

The developed hardware fulfils the requirements necessary for a data signal processing system. This hardware scales the actual signal from the electrical network, and keeps all the features. For this purpose it is necessary to maintain certain design criteria:

1. *Reduction of the power signal:* The acquisition of power electrical signal of 400/240 Vrms must be scaled to small signal values ($\pm 10V$) for the processing system.
2. *Linear scaling of the power signal:* The use of transformers must be avoided, because transformers are non-linear, and are a source of disturbances when they are measuring.
3. *Bandwidth equipment determination:* The cut-off frequency of the sensors must be greater than the measured frequency values.
4. *Uncoupling the signals:* The input power electrical signal must be uncoupling of small measurement signal.
5. *The election of a sufficiently fast system for the data acquisition:* The sampling frequency must be much higher than the measured frequencies.
6. *Continuity in the data capture:* The memory buffer and the processor must be complemented, for the speed of processing of the acquired signal to allow continuous data capture in real time.

Two processes well different are identified. The first of them is called 'Signal Conditioning' and it corresponds to the points one to four. It consists of transforming the network original signal to a small signal. A prototype can be seen in figure 7. The second process is called 'Signal Acquisition' and corresponds to the points 5 and 6. It transfers the small signal to the data processing system.

An acquisition system PCMCIA NI-DAQcard-606E. has been used.

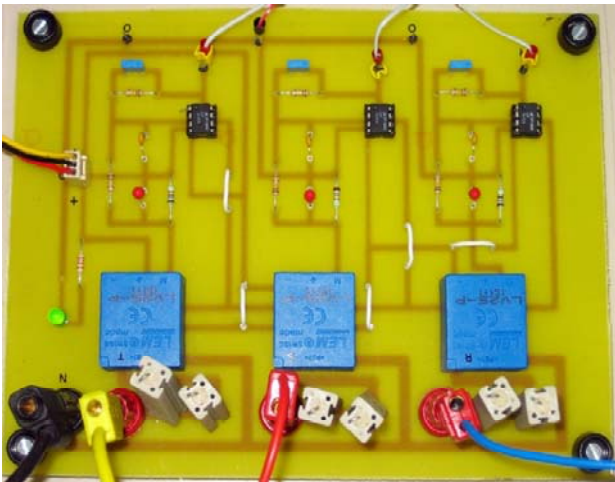

Fig. 7. Signal Conditioning hardware prototype

G. Results

Several signal disturbances have been generated in order to check the implemented system performance.

The system has been excited externally with values whose wavelet decomposition has been simulated, and later the actual response has been verified.

In Figure 8 can be seen a momentary interruption of 200ms. The Wavelet decomposition realized with the AMR algorithm is presented. In the figure can be seen the five detail signals corresponding to the frequency levels 1.600-800 Hz, 800-400 Hz, 400-200 Hz and 200-100 Hz and 100-50 Hz.

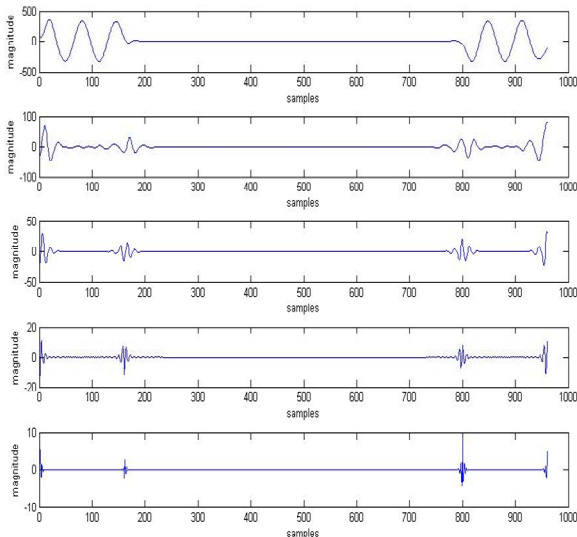

Fig. 8. Wavelet Decomposition Simulation

In order to verify the perfect system performance, the same simulated signal has been introduced and the results are compared.

A measurement protocol has been designed in order to interfere as less as possible in the analysis process.

The results obtained from the record created by the program of detection of disturbances referred in the section (d) are according to the IEEE1159 standard.

The following graphics are the results of the test of momentary interruption of 200ms. The abscissa axis is scaled to the sampling frequency and it is indicated at the top of the graphics. The maximum frequency of the signal of coefficients wavelets is half of the sampling frequency. See figures (9, 10, and 11) below, for results at 3.2kHz sampling rate.

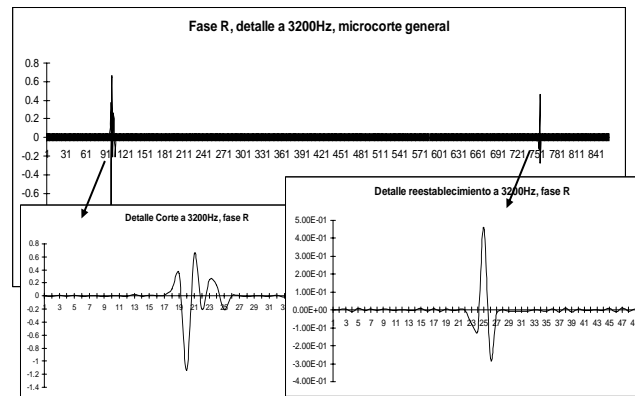

Fig. 9. Momentary interruption. 3.2kHz of sampling rate, R phase

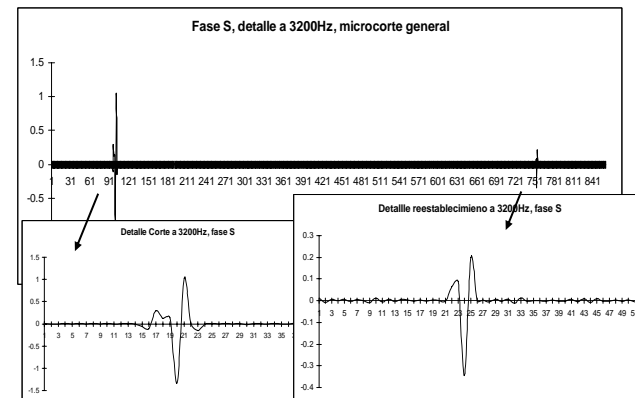

Fig. 10. Momentary interruption to 3.2kHz of sampling rate, S phase

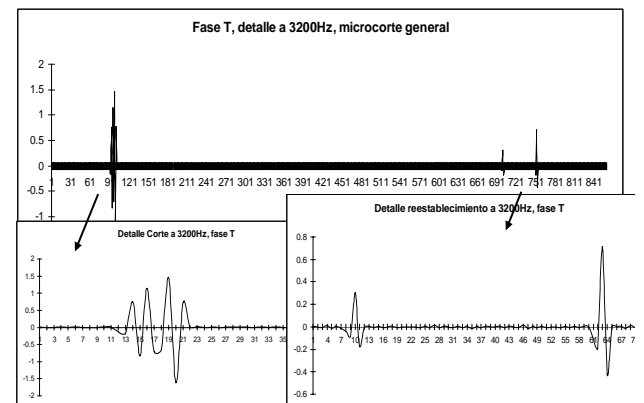

Fig. 11. Momentary interruption to 3.2kHz of sampling rate, T phase

The figure 13 results for 1.6kHz sampling rate on 'T' phase, and de half of sampling rate for the successive decompositions for the figures 14, 15 and 16 are shown.

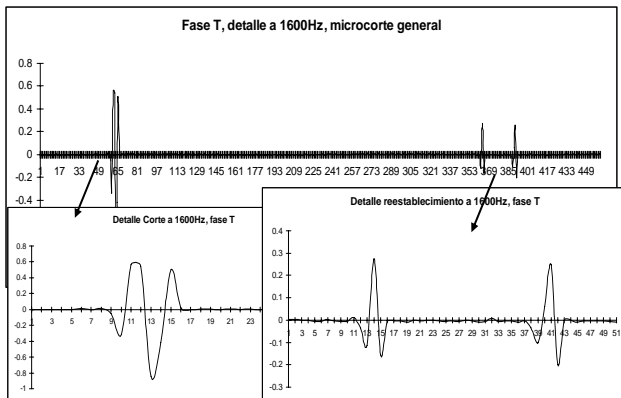

Fig. 13. Momentary interruption to 1.6khz of sampling rate, T phase

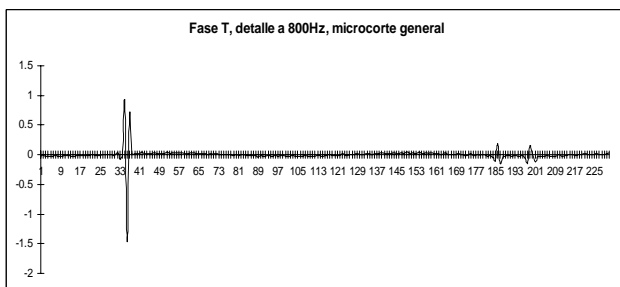

Fig. 14. Momentary interruption to 0.8khz of sampling rate, T phase

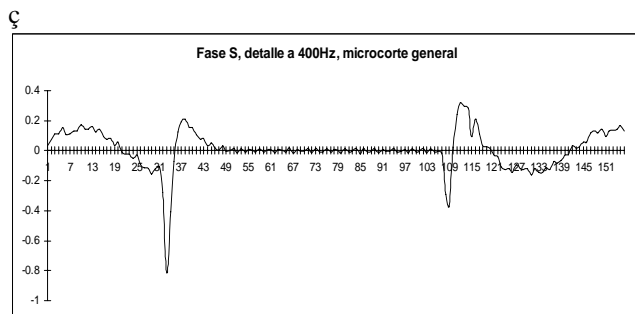

Fig. 15. Momentary interruption to 0.4khz of sampling rate, S phase

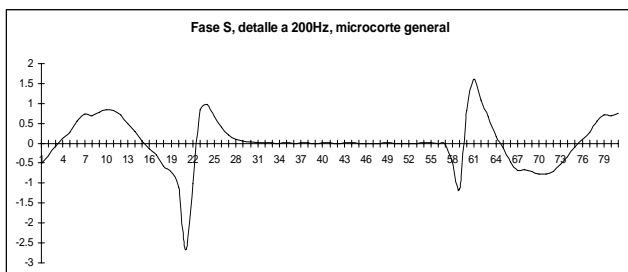

Fig. 16. Momentary interruption to 0.2khz of sampling rate, S phase

Another series of experiments has been made, such as connection of capacitive loads. Characteristic variations in the discharge decompositions and average frequency have been detected.

3. Conclusions

The designed system is an effective and advanced method of detection of disturbances in the electric network.

The method separates the disturbances produced in different frequencies and magnitudes.

The method can characterize each type of disturbance with 15 different components.

The proposed method is easy and simply to implant.

That the registered data can be used for training of artificial intelligence networks.

It is necessary to consider that the computing time will limit this method to solve certain transitory problems of the electric network, although always they will be detected and they could be evaluated.

4. References

- [1] Phadke,A.G. and Thorp,J.S. *Computer Relaying for Power Systems*. John Wiley and Sons. New York, 1998.
- [2] Burrus, C.S., Gopinath, R.A., Guo, H. *Introduction to Wavelets and Wavelet Transforms*. Prentice Hall. New Jersey, 1998
- [3] Borrás, D.,Castilla, M., Moreno, N., Montañó, J.C. *Análisis y Clasificación de Variaciones de Tensión Utilizando la Transformada Wavelet*. Simposio Iberoamericano sobre Protecciones de Sistemas Eléctricos de Potencia. Monterrey, México, Noviembre 2000.
- [4] S. Chen and H. Y. Zhu *Wavelet Transform for Processing Power Quality Disturbances* EURASIP Journal on Advances in Signal Processing Volume 2007, Article ID 47695, 17 February 2007
- [5] J. Liang; S. Elangovan; J.B.X Devotta. *Applications of Wavelet Transform in Travelling Wave Protection*. Electrical Power and Energy System ELSEVIER, Vol.22, pp.537-542, 2000.