

Application of Genetic Algorithms to Compute the Magnetic Field Produced by Electric Power Lines

F. Muñoz, J.A. Aguado, F. Martín, J.J. López, A. Rodríguez and J.E. Ruiz

Department of Electrical Engineering
E.T.S.I.I. - E.U.P., Málaga University
Campus El Ejido - 29013 Málaga (Spain)
Phone/Fax number: +0034 952 131091

e-mail: fjmg@uma.es, jaguado@uma.es, fimartin@uma.es, jjlopez@uma.es, arodriguezg@uma.es, jeruiz@uma.es

Abstract. In this paper the authors present a procedure, based on a genetic algorithm, to estimate the longitudinal and cross-sectional profiles that characterize their electromagnetic environment, by using a limited number of the available magnetic field measures produced by electric power lines (EPL).

The validation of the considered values is made for different line configurations and taking as reference the measured values and the theoretical ones calculated by the described analytical procedure in [1].

Key words

Magnetic field measurement, Genetic algorithms, Transmission lines.

1. Introduction

A. Preliminary considerations

In the elaboration of electromagnetic contamination reports corresponding to the fieldworks developed, it was observed that, the measured values of magnetic flux density (B) differed, in some cases, from the theoretical values. This difference between measured and theoretical values may have a very diverse origin, which can be due to the confluence of factors, such as:

- Measurement errors (e.g. due to the calibration, equipment direction to make it agree with the axis of reference system, etc).
- Changes, whethert transitory or stationary, of EPL load conditions.
- Waveform distortions.
- Environmental conditions changes (temperature, humidity, etc).
- Influence of environmental electromagnetic contamination.

In addition, if we considered that the existence of buidings, deprived properties, unevennesses, etc., in EPL proximities averts, in numerous occasions, to complete the IEEE Std 644 [2], the measurement protocol corresponding of the magnetic field produced by these EPL. Therefore, it becomes necessary to establish a procedure that, taking the available measured values as reference, allows us to consider the rest of measures, the theoretical values being valid only as referential to verify that the resulting error between the measured and estimated values is minor than the error between the measured and the theoretical values.

B. About this work

The solution that the present work affords, consists in obtaining a function (reduced equivalent equation REE), that generates the values measured, dependent on the distance to which the measure is estimated.

The searched function will be identified (obtaining the linear and nonlinear coefficients present in the same) using the available measured values corresponding to the IEEE Std 644 protocol, by which are certain to have the necessary data, to make comparative studies.

Once the function has beeing idetified, it suffices to replace the value of a certain distance to obtain the value of the required measurement.

After making numerous tests with different functions (polynomic, quadratic, trigonometrical, exponential, etc), we concluded that it was an exponential function the one that, with a smaller accumulated error (norm), allowed the best adjustment to measure the curve.

$$B_m = \sum_{j=1}^n L_j \cdot e^{-NL_j \cdot x^2} \quad (1)$$

At least we need to establish a solution of commitment between the approximation to obtain (the validity of the solution contributed) and to the calculation complexity of present parameters in exponential function terms. In our case, we can assure that the results a acceptable with the length of two terms.

Lj (linear coefficients) and NLj (nonlinear coefficients) are the parameters that must be estimated. Variable x represents the distance to which the measurement is made.

The identification of the linear and nonlinear coefficients presents in the reduced equivalent equation (REE) must be calculated optimizing their value to obtain that the accumulated error (norm) between the values, measured and estimated using the REE, is minimum.

2. REE identification

The identification of the linear and nonlinear coefficients present in the REE is made using a genetic algorithm, whose characteristics are the following:

- Population size: 100 individuals.
- Fitness: Euclidean norm between measured and estimated values.
- Selection operator: Uniform stochastic.
- Mutation operator: Gaussian function.
- Crossover operator: Unique point.
- Stopping criteria: Stall (20 generations).

3. Validation

For the validation of the obtained results, different configurations of lines, either of simple circuit or double circuit, have been chosen.

A. Line 1 (380 KV, simple circuit flat)

The geometric characteristics are in Figure 1.

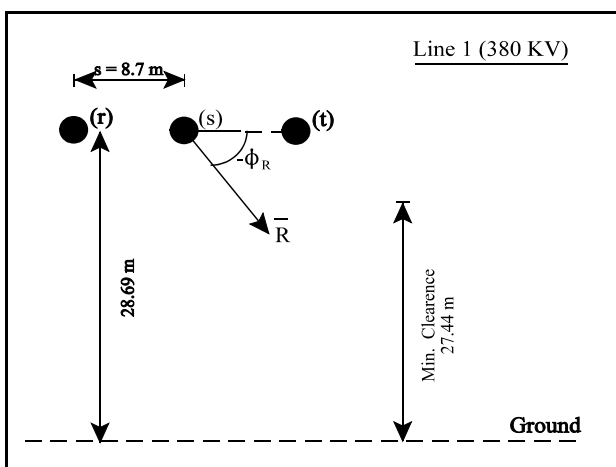

Fig 1. Line 1 (geometric characteristics)

The analytical method used for the calculation of the theoretical values is described in [1] using double complex numbers.

$$B_t = \frac{\mu_0 \cdot I \cdot s}{2 \cdot \pi \cdot R} \cdot \left(\frac{3 \cdot R^2 + s^2}{R^4 - 2 \cdot R^2 \cdot s^2 \cdot \cos(2 \cdot \varphi_R) + s^4} \right)^2 \quad (2)$$

The application of the genetic algorithm to the measures available produces the result shown in Table I.

TABLE I. - Line 1 (coefficients)

COEFFICIENTS	VALUES
L1	$2.9971 \cdot 10^{-1}$
L2	1.1455
NL1	$-1.8326 \cdot 10^{-4}$
NL2	$1.25663 \cdot 10^{-3}$

Replacing these coefficients in the REE, the cross-sectional section (at the tower base) shown in Figure 2 is obtained:

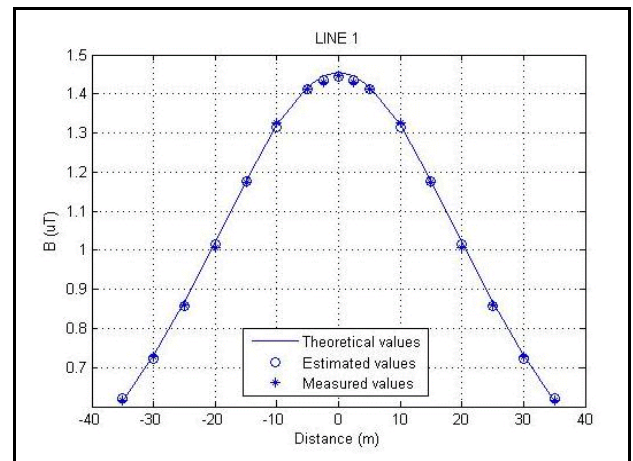

Fig 2. Line 1 (comparison of values)

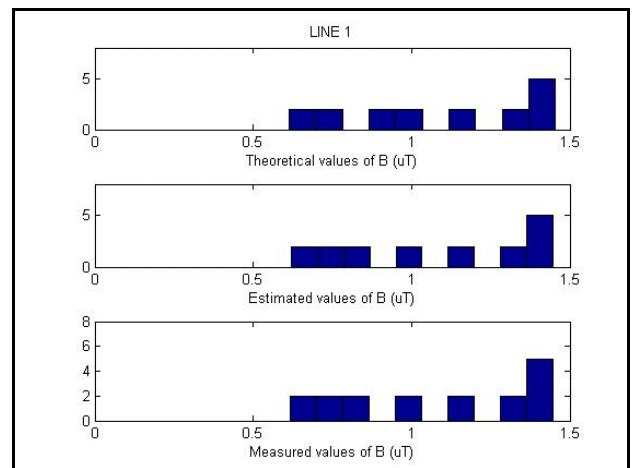

Fig 3. Line 1 (histograms)

The histogram of Figure 3 shows, for the cross-sectional section of Figure 2, the distribution of estimated and theoretical values obtained.

The following figure shows the reconstruction of the longitudinal profile corresponding to line 1.

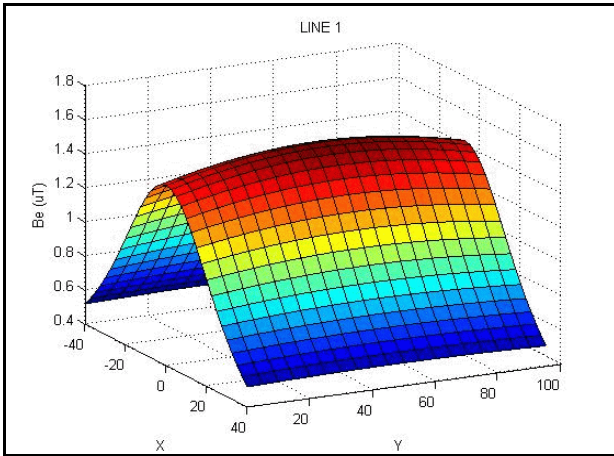

Fig 4. Line 1 (longitudinal section)

B. Line 2 (66 KV, double circuit)

The geometric characteristics are in Figure 5.

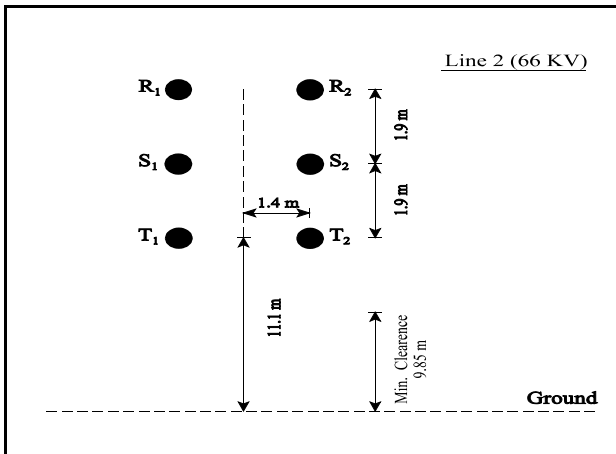

Fig 5. Line 2 (geometric characteristics)

The application of the genetic algorithm to the measures available produces the result shown in Table II.

TABLE II. - Line 2 (coefficients)

COEFFICIENTS	VALUES
L1	1.0461
L2	6.36492×10^{-1}
NL1	7.43103×10^{-3}
NL2	9.613×10^{-4}

Replacing these coefficients in the REE, the cross-sectional section (at the tower base) shown in Figure 6 is obtained.

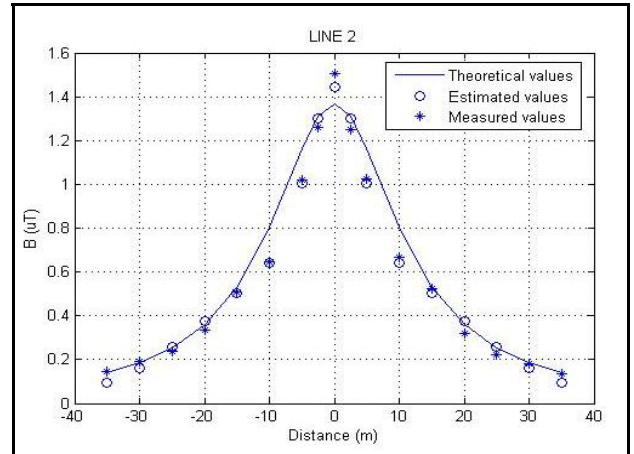

Fig 6. Line 2 (comparison of values)

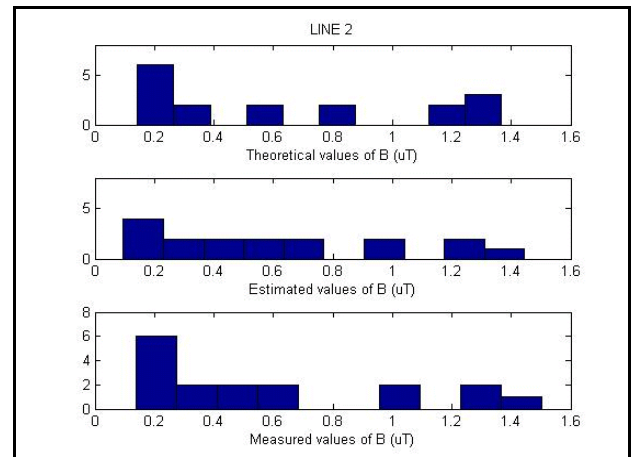

Fig 7. Line 2 (histograms)

The histogram of Figure 7 shows, for the cross-sectional section of Figure 6, the distribution of estimated and theoretical values obtained.

The following figure shows the reconstruction of the longitudinal profile corresponding to line 2.

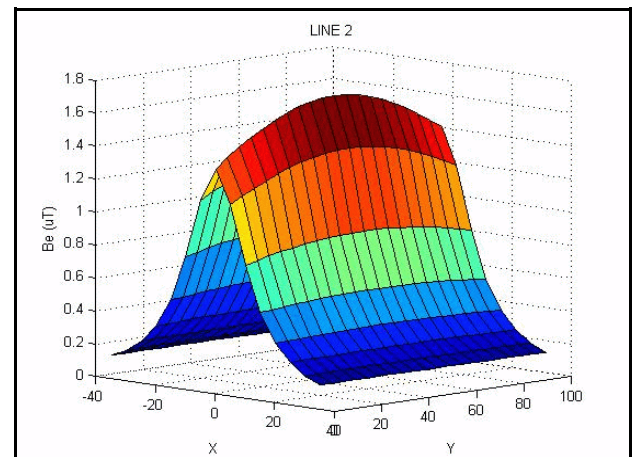

Fig 8. Line 2 (longitudinal section)

C. Line 3 (132 KV, double circuit)

The geometric characteristics are in Figure 9.

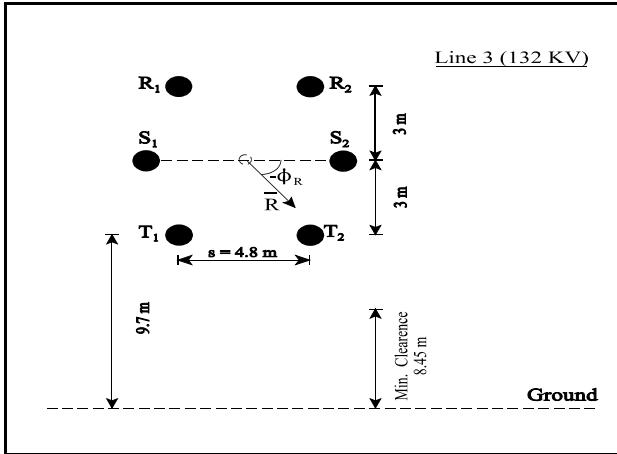

Fig 9. Line 3 (geometric characteristics)

The analytical method used for the calculation of the theoretical values is described in [1] using double complex numbers.

$$B = \frac{\mu_0}{2 \cdot \pi} \cdot \frac{N}{\left(R^{12} - 2 \cdot R^6 \cdot s^6 \cdot \cos(6 \cdot \varphi_R) + s^{12} \right)^{1/2}} \quad (3)$$

$$N = 3 \cdot I \cdot s \cdot \left[R^8 + s^2 \cdot R^6 + 2 \cdot s^4 \cdot R^4 \cdot (\cos 2 \cdot \varphi_R - \cos 4 \cdot \varphi_R) + s^6 \cdot R^2 + s^8 \right]^{1/2} \quad (4)$$

The application of the genetic algorithm to the measures available produces the result shown in Table III.

TABLE III. - Line 3 (coefficients)

COEFFICIENTS	VALUES
L1	1.0461
L2	6.36492@0 ⁻¹
NL1	7.43103@0 ⁻³
NL2	9.613@0 ⁻⁴

Replacing these coefficients in the REE, the cross-sectional section (at the tower base) shown in Figure 10 is obtained.

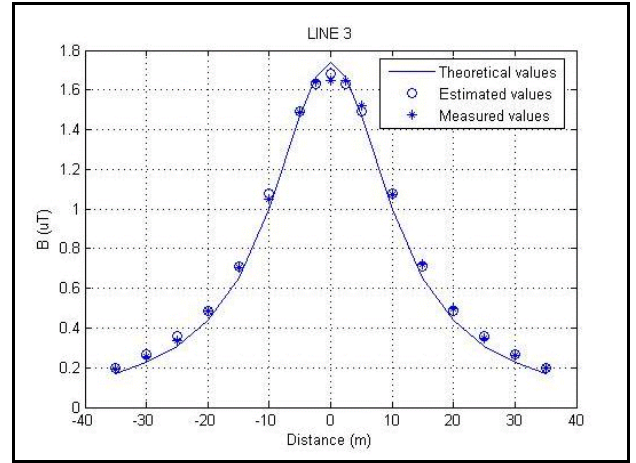

Fig 10. Line 3 (comparison of values)

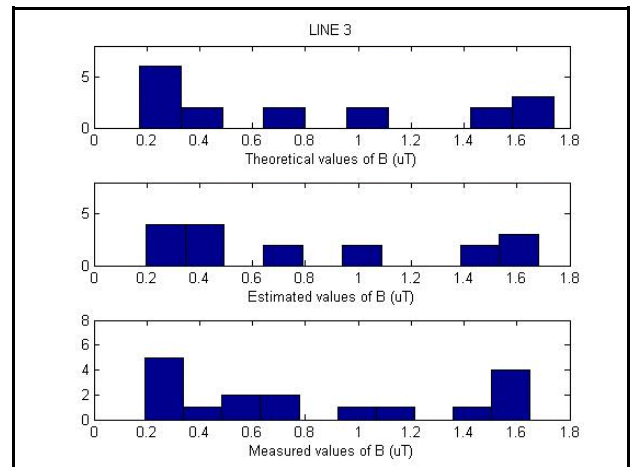

Fig 11. Line 3 (histograms)

The histogram of Figure 11 shows, for the cross-sectional section of Figure 10, the distribution of estimated and theoretical values obtained.

The following figure shows the reconstruction of the longitudinal profile corresponding to line 3.

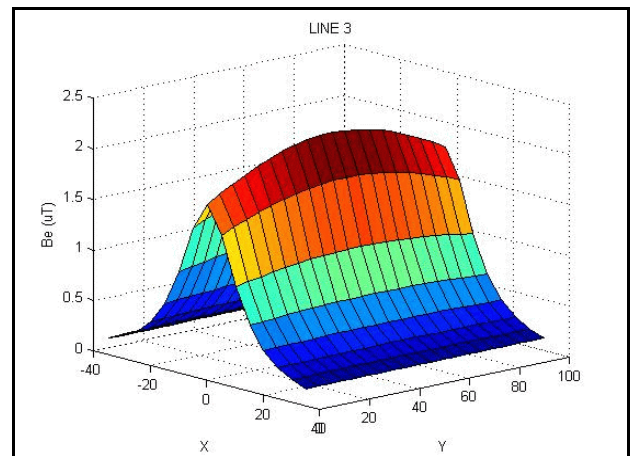

Fig 12. Line 3 (longitudinal section)

4. Conclusion

A new procedure has been presented to characterize the EPL electromagnetic environment using a limited number of measures so that they allow us to complete IEEE Std 644 protocol.

The following table is a comparative study between the solution corresponding to theoretical calculation (first column) of magnetic field generated by different lines and the proposed procedure using a limited numbers of measures (second column).

TABLE IV. - Comparison of values

	NORM (Bt-Bm)	NORM (Be-Bm)
Line 1 (380 KV)	0.0373	0.0238
Line 2 (66 KV)	0.3388	0.1467
Line 3 (132 KV)	0.1974	0.0633

The numerical results obtained in the validation, for different lines allow us to state that the proposed procedure application contributes to considerable improvements on the theoretical calculation.

References

- [1] G. Filippopoulos and D. Tsanakas, "Analytical calculation of the magnetic field produced by electric power lines", IEEE Trans. On Power Delivery, Vol. 20, No. 2, pp 1474-1482, April 2005.
- [2] IEEE Std 644. Procedures for measurement of power frequency electric and magnetic fields from AC power lines, The Institute of Electrical and Electronics Engineers, Inc., January 1995.
- [3] S. Ozen, "Evaluation and measurement of magnetic field exposure at a typical high-voltage substation and its power lines", Radiation, Protection and Dosimetry, No. 327, pp 1-8, May 2007.