

Analysis by State Equation of a Control Strategy for Hybrid Filter

S. P. Litrán, P. Salmerón, J. R. Vázquez

Departamento de Ingeniería Eléctrica y Térmica
Escuela Politécnica Superior, Universidad de Huelva
Ctra. de Palos de la Frontera s/n, 21819, Palos de la Frontera, Huelva, Spain
Phone: +34-959217585, Fax: +34-959217304
e-mail: salvador@uhu.es; patricio@uhu.es; vazquez@uhu.es

Abstract. A control algorithm is proposed for a three-phase hybrid power filter constituted by a series active filter and a passive filter connected in parallel with the load. It is based on the dual formulation of the vectorial theory of instantaneous reactive power, so that the voltage waveform injected by the active filter is able to compensate the reactive power and the harmonics of the load current. System state model was obtained and the system behaviour was analyzed by the state equations for each situation. The analysis developed has allowed the knowledge of the system dynamic behaviour and the stability margins. An experimental prototype has been developed, and simulation and experimental results are presented.

Key words

Harmonics, series active power filter, hybrid filter, state space.

1. Introduction

The active power filters (APFs) have been used in the last years to eliminate the harmonic distortion in electrical systems. An APF is a static compensation system based on an electronic converter with a Pulse Width Modulation (PWM) control. It may be connected in parallel or in series to the load. The shunt APF is connected in parallel to the load and it works as a controlled current source. These equipments allow the elimination of the current harmonic originated by the called current harmonic source loads [1,2]. It is the most studied configuration.

To eliminate current harmonics a shunt passive filter have traditionally been used, mainly due to their low cost and minimal maintenance requirements. As a result, this has been the adopted solution for systems with considerable power. It is possible to improve the behaviour of shunt passive filters including a series active filter in the system. This improves the compensation characteristics of the passive filter, [3]. This topology is

shown in figure 1, where v_c is the voltage that the active power filter should generate to achieve the objective of proposed control algorithm.

Different strategies have been applied to this topology, according to the compensation target [4,7]. This work is focused on the analysis of a control strategy based on the dual formulation of the vectorial theory of electrical power, [8,9]. The voltage waveform injected by the active filter is able to compensate the reactive power and the harmonics of the load current. A state model of the system has been developed. This analysis has allowed the knowledge of the system dynamic. The system behaviour has been contrasted by means of a laboratory prototype and experimental results have been presented.

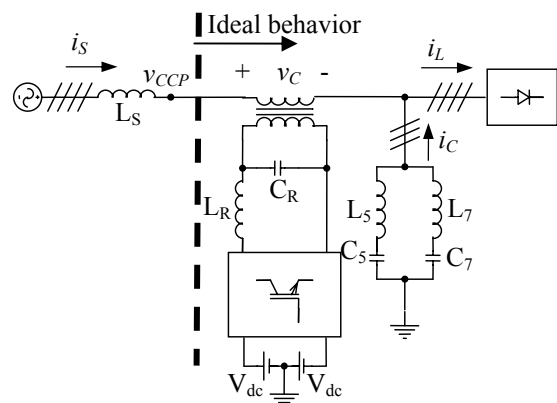

Fig. 1. Scheme of a hybrid filter, series active filter and shunt passive filter

2. Compensation Strategy and state equations

Electrical companies try to generate electrical power with sinusoidal and balanced voltages and it has been considered as a reference condition in the supply. Due to this fact, the compensation target is based on an ideal

reference load which must be resistive and linear. It means that the source currents are collinear to the supply voltages, and the system will have unity power factor. This is

$$\mathbf{v} = R_e \mathbf{i} \quad (1)$$

Where R_e is the equivalent resistance, \mathbf{v} the voltage vector on the connection point and \mathbf{i} the load current vector.

The reference signal for the output voltage of the active filter is

$$\mathbf{v}_C^* = \mathbf{v}_{PCC} - \mathbf{v}_L = \frac{P_L}{I_1^2} \mathbf{i} - \mathbf{v}_L \quad (2)$$

Here, I_1^2 is the square rms value of the fundamental component, \mathbf{i} is the source current vector, P_L is the load average power and \mathbf{v}_L is the load average power.

When the active filter supplies the compensation voltage, the set load and compensation equipment will behave as a resistor with a R_e .

An equivalent single-phase model of the circuit shown in figure 1 is used to analyze, the system behaviour. The state equations were obtained. The bode diagram of these equations allows the analysis for different situations and inputs. The state equation also let the analysis of poles and zeros to study the system stability.

An experimental prototype was developed. This allows verification of the developed theoretical analysis. Table I summarizes some measures for a phase.

TABLE I. Experimental results, phase a

	Without compensating		With passive filter		With active and passive filter	
	V	I	V	I	V	I
THD %	8.7	26.8	7.4	31.5	1.3	2.7
RMS(A)	97.4	5.9	99.3	5.9	98.6	5.5
Fund.(A)	97	5.7	99	5.6	98.6	5.5
H3 (A)	4.2	1.2	5.7	1.7	0.5	0.1
H5 (A)	3.8	0.7	2	0.4	0.1	0
H7 (A)	3.4	0.5	0.8	0.1	0.1	0
H9 (A)	3	0.3	1.6	0.9	0.1	0
P(kW)	0.54		0.56		0.55	
Q(kvar)	0.17(i)		0.03(c)		0.00	
S(kVA)	0.56		0.56		0.55	
PF	0.91		0.94		1	

3. Conclusion

A control algorithm for a hybrid power filter constituted by a series active filter and a passive filter connected in parallel with the load is proposed. The control strategy is based on the dual vectorial theory of electric power. System state model has been obtained and the system behaviour has been analyzed from the state equations for each situation. The analysis developed has allowed the knowledge of the system dynamic behaviour and the stability margins in each situation. This allowed an experimental prototype to be developed.

The new control approach achieves the following targets:

- The hybrid filter and load set are behaviour resistive. This fact eliminates the risk of overload due to the current harmonics of non-linear loads close to the compensated system.
- Series and/or parallel resonances with the rest of the system are avoided because compensation equipment and load are resistive behaviour.
- The active filter improves the harmonic compensation features of the passive filter and compensates the reactive power, achieving unit power factor.

Experimental and simulation results are presented. This allows verification of the developed theoretical analysis.

Acknowledgement

This work is part of the projects "A new technique to reduce the harmonic distortion in electrical systems by means of equipment of active compensation", ref. DPI2004-03501, sponsored by the "Comisión Interministerial de Ciencia y Tecnología, CICYT, del Ministerio de Ciencia y Tecnología" of Spain, and "Design and implementation of a new equipment of active compensation with series connection for the improvement of the electrical waveform quality", ref. P06-TEP-02354, sponsored by the "Consejería de Innovación, Ciencia y Empresa de la Junta de Andalucía", of Andalucía, Spain.

References

- [1] F. Z. Peng and D. J. Adams, "Harmonics sources and filtering approaches," in Proc. *Industry Applications Conference*, October 1999, Vol, 1, pp. 448-455.
- [2] H. Akagi, "Active harmonic filters," *Proceedings of the IEEE* Volume 93, Issue 12, Dec. 2005 Page(s):2128 – 2141.
- [3] F. Z. Peng, H. Akagi, A. Nabae, "A novel harmonic power filter," in Proc. *IEEE/PESC*, April, 1988, pp. 1151-1159.
- [4] F. Z. Peng, H. Akagi, A. Nabae, "A new approach to harmonic compensation in power systems-a combined system of shunt passive and series active filters," *IEEE Trans. Industry Applications*. Vol, 26, no. 6, Nov/Dec 1990, pp. 983-990.
- [5] Y. S. Kim, J. S. Kim and S. H. Ko, "Three-Phase Three-Wire Series Active Power Filter, which Compensates for Harmonics and Reactive Power", *IEE proc. Electr. Power Appl.*, Vol, 151, no. 3, May 2004, pp. 276-282.
- [6] Z. Wang, Q. Wang, W. Yao and J. Liu, "A series active power filter adopting hybrid control approach," *IEEE Trans. Power Electronics*, vol. 16, no. 3, May 2001, pp. 301-310.
- [7] S. P. Litrán, P. Salmerón, J. R. Vázquez and R. S. Herrera, "Different control strategies applied to series active filters", in Proc. *ICREPO*, May, 2007.
- [8] F. Z. Peng, J. S. Lai, "Generalized instantaneous reactive power theory for three phase power system", *IEEE Trans. Instrum. Meas.* 1996, 45, (1), pp. 293-297.
- [9] Herrera, R. S.; Salmerón, P.; Kim, H.; "Instantaneous Reactive Power Theory Applied to Active Power Filter Compensation: Different Approaches, Assessment, and Experimental Results", *IEEE Transactions on Industrial Electronics*, Vol. 55, No. 1, Jan-2008, pp: 184 – 196.